



**HAL**  
open science

# Optimal Invariant Observers Theory for Nonlinear State Estimation

Jean-Philippe Condomines, Cédric Seren, Gautier Hattenberger

► **To cite this version:**

Jean-Philippe Condomines, Cédric Seren, Gautier Hattenberger. Optimal Invariant Observers Theory for Nonlinear State Estimation. Edited by Fourati Hassen Belkhiat Djamel Eddine Chouaib Iniewski Krzysztof. Multisensor Attitude Estimation Fundamental Concepts and Applications Edited by Fourati Hassen Belkhiat Djamel Eddine Chouaib Iniewski Krzysztof, Taylor & Francis, pp 391-408, 2016, 978-1-4987-4571-0, eBook ISBN: 978-1-4987-4580-2. hal-01395580

**HAL Id: hal-01395580**

**<https://enac.hal.science/hal-01395580v1>**

Submitted on 5 Oct 2017

**HAL** is a multi-disciplinary open access archive for the deposit and dissemination of scientific research documents, whether they are published or not. The documents may come from teaching and research institutions in France or abroad, or from public or private research centers.

L'archive ouverte pluridisciplinaire **HAL**, est destinée au dépôt et à la diffusion de documents scientifiques de niveau recherche, publiés ou non, émanant des établissements d'enseignement et de recherche français ou étrangers, des laboratoires publics ou privés.

*J-P. Condomines, C. Seren and G. Hattenberger*

---

***Optimal Invariant  
Observers Theory for  
Nonlinear State  
Estimation***

---

## *List of Figures*

---

23.1	Classification of nonlinear state estimation methods . . . . .	2
23.2	Moving frame illustration . . . . .	9
23.3	Academic example of the nonholonomic car . . . . .	10
23.4	State space topological equivalence . . . . .	11
23.5	<b>IUKF</b> vs. <b>UKF</b> : estimates and errors magnitude comparison	20
23.6	<b>IUKF</b> vs. <b>UKF</b> : correction gains and error convergence . .	20

# 23

---

## *Optimal Invariant Observers Theory for Nonlinear State Estimation*

---

### CONTENTS

23.1	General Introduction .....	1
23.1.1	Nonlinear Invariant State Estimation: A Brief Review ..	1
23.1.2	Chapter Outline .....	4
23.1.3	Mathematical Notations .....	5
23.2	Dynamical Systems Possessing Symmetries .....	5
23.2.1	Theoretical Background .....	5
23.2.2	Notion of Invariant .....	8
23.2.3	Academic Example .....	9
23.3	Optimal Invariant Nonlinear State Estimation .....	11
23.3.1	Invariant Observer .....	11
23.3.2	Invariant UKF: Principles and Design .....	14
23.4	Benchmark and Application .....	16
23.4.1	Dynamic System Modeling .....	16
23.4.2	IUKF Estimator Design .....	17
23.4.3	Results .....	19

---

### 23.1 General Introduction

#### 23.1.1 Nonlinear Invariant State Estimation: A Brief Review

Many recent progresses in the field of sensors miniaturization have led to the design of small and cheap integrated navigation system hardwares (complete **IMU**, **GPS** module, etc.), which have, for their part, contributed to boost significantly the market of mini-**UAVs** over the last decades, making them more accessible to everyone. Nevertheless, this accessibility is frequently inconsistent with good measurement performances. For instance, the **GPS** modules used commonly in the Paparazzi autopilot (cf. Paparazzi project at: <https://wiki.paparazziuav.org/>) deliver a position with an average accuracy of 5 meters, up to 10m under certain flight conditions. Therefore, a need for multisensor data fusion arises, especially when the objective consists in developing robust advanced control strategies for mini-**UAVs**. To this aim,

*nonlinear estimation* offers several well-proven algorithmic techniques which permit to recover an acceptable level of accuracy on some key flight parameters (anemometric angles, orientation/attitude, linear and angular speeds, position, etc.) for mini-UAVs closed-loop handling qualities. An overview of nonlinear estimation methods can be found in the literature from many surveys or books (see [1–3] for example). Fig. (23.1) attempts to propose a classification of these latter and positions chapter 23 topic in it (white terms in grey boxes). As they merge different nonlinear estimation principles, *optimal invariant observers* can be qualified as hybrid filters. Although dynamical

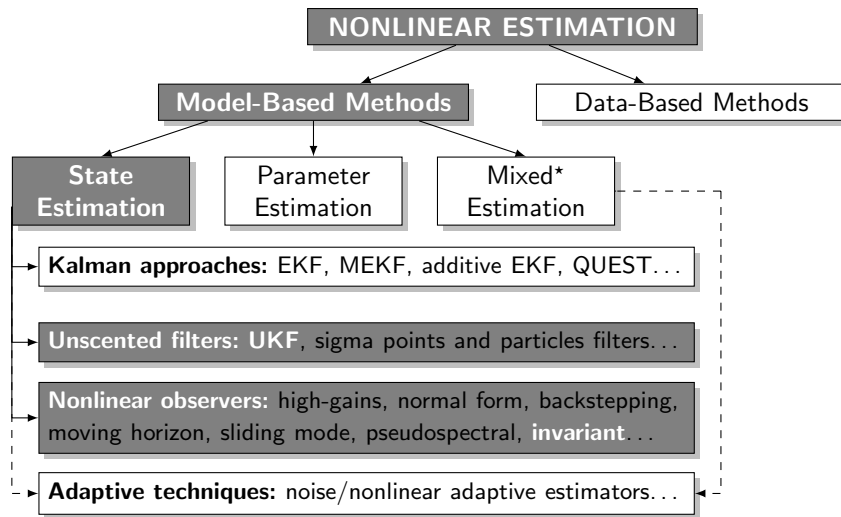

\* "Mixed" means joint state/parameter estimation.

**FIGURE 23.1**

Classification of existing nonlinear state estimation techniques and chapter 23 topic positioning.

systems possessing symmetries have been studied in control theory, few results taking benefit of system invariances for observers design exist today. Invariant nonlinear estimation theory appears so as a young research area in which the first main contributions can be dated from the beginning of 2000s (see [4–20] and the references therein). Initially, research was going on in the development of constructive methods to derive invariant observers for nonlinear estimation purposes which preserve systems' symmetries. If this kind of non-systematic approaches keeps physical readiness, it requires however to tune an important number of setting parameters potentially when computing estimation gains, which can be cumbersome for complex system modelings. That is why, researchers have then tried to develop more systematic techniques which are able to facilitate estimators' gains computation. The **Invariant Extended Kalman**

Filter (**IEKF** - cf. bibliographical references [7,10]) permits to determine gain matrices for minimum variance estimation. This optimality must be considered here w.r.t. an invariant state estimation error which will be defined precisely further. An important drawback in this method is that it requires to linearize a system of differential equations which govern the invariant state estimation error dynamics. Such an operation appears suitable for simple system modelings only s.t. **UAVs** whose dynamics can be represented easily based on kinematics relationships. Indeed, this kind of nonlinear state space representation can be differentiated analytically towards its state vector. For more complex system modelings, this linearization may be difficult to carry out. Nevertheless, the **IEKF**, and more generally invariant observers, are characterized by a larger convergence domain, due to the exploitation of systems' symmetries within the estimation algorithm (*i.e.*, within filter equations and gains computation), and present very good performances in practice. In order to derive more tractable algorithms for nonlinear invariant state estimation, an hybridation of the Unscented **KF** (**UKF**) principles (cf. [21–24]) with invariant observers theory has been recently proposed in [12, 13, 20]. Among other things, it has been proved in these bibliographical references that an Invariant **UKF**-like estimator (named **IUKF**) could be simply designed by introducing both notions of invariant state estimation and invariant output errors within any **UKF** algorithm formulation (standard version or square-root/UD factorized ones - see [25, 26]). Besides, it has been shown that, for some well-known navigation problems devoted to **UAVs**, equations of any **IUKF**-based observer in discrete-time could be expressed quite simply. Indeed, state vector estimate can be determined recursively and approximated by a weighted linear combination of  $n \in \mathbb{N}^*$  invariant estimates. This chapter relies strongly on these recent research works and more details about them will be explained in the sequel. Similarly, an extension of nonlinear invariant observers has been made for Rao-Blackwellized **P**article **F**ilters (**PF**) that can be used for nonlinear state estimation (cf. [14]). Invariant **PFs** (**IPF**) rely on the notion of *conditional invariance* which corresponds to classical system invariance properties, but once some state variables are assumed to be known. It is those known states that will be sampled throughout the estimation process. The observer structure is actually double. Indeed, the rest of the state variables are marginalized out using **IEKFs**. It is noteworthy that, for the obtained **IPF**, the Kalman gains computed are identical for all particles which drastically reduces the computational effort usually needed to implement any **PF**.

All the previous estimation methodologies have allowed the invariant observers theory to be applied in many various application fields since the beginning of the 2000s. Rather than enumerating all of them, which would be out of the scope of this chapter, we prefer focusing here on the use, become popular in the domain of robotics, of the invariant observers for solving nonlinear attitude estimation problems from both inertial/vision multisensors data fusion. Many bibliographical references, such as for instance [18, 27, 28], tackle this specific

issue exploiting nonlinear invariant observers. Both properties and capabilities of this peculiar class of method make any invariant observer-based estimation scheme dedicated to dynamical system navigation appealing, especially when there exists, in addition, hardware redundancy. In that case, automated vehicles can reach an acceptable level of robustness w.r.t. degraded operating conditions such as, for example, in indoor or **GPS**-denied environments, and in case of single or multiple sensor faults. Using an invariant observer-based algorithm to merge an extended (and potentially redundant) set of measurements can still provide good performances and convergence properties in such situations.

Another interesting application of invariant observers theory can be found in [29]. It reformulates the standard **Linear Quadratic Gaussian (LQG)** controller synthesis into an **Invariant LQG (ILQG)** design by making use of an **IEKF** for the observer part. This leads to marginally modify the standard equations of the **LQG** synthesis in order to account for, and to exploit, system's symmetries and invariances. The resulting controller appears to be more robust and less sensitive to both estimated trajectory and misestimates. Such an **ILQG**-based observer-controller design offers new interesting solutions and opens new perspectives for motion planning applied to robotics.

### 23.1.2 Chapter Outline

This chapter aims at introducing the basics of optimal nonlinear invariant state estimation to engineers, research scientists and applied mathematicians. Although it gathers some new theoretical results, this chapter tries to expand upon the past treatments of both invariant observers theory and **UK** filtering, to provide a more comprehensive view on recent developments and updates in the domain. Chapter redaction should be accessible to both senior undergraduate and 1<sup>st</sup> graduate students, and should prove to be well-suited for practicing professionals. Chapter contributors expect that this text will minimize newcomers' pain in assimilating and applying all the theoretical concepts presented. By underlying the links between differential geometry and dynamical systems modeling, it is hoped that the content will be also of perennial interest for students, scholars and engineers working in various disciplines. This work has been also motivated by the practical problems encountered by the authors with the subject for **UAVs** flight control and guidance, civil **A/C** modeling and identification and dynamic system fault detection, isolation and recovery.

The present chapter is organized as follows. Section 23.2 starts with the presentation of fundamental theoretical prerequisites dealing with both differential geometry and group theory. A permanent connection of the different mathematical concepts introduced so far with a generic system representation is made. Then, the notion of invariant for dynamical systems possessing symmetries is introduced in §23.2.2. An academic example, illustrating the whole theoretical background, ends this introductory part in a third step.

The 1<sup>st</sup> part of section 23.3 is devoted to invariant observers theory. The general form of the invariant observer is then specialized, and the **IUKF** is naturally introduced in paragraph 23.3.2.

Section 23.4 illustrates the performances reached by the developed **IUKF** algorithm, by solving the non-aided **AHRS** navigation problem, in the case of an automated free-falling parafoil vehicle.

### 23.1.3 Mathematical Notations

$(\Sigma_{(d)}, f_{(d)}/h_{(d)})$	Continuous (discrete) system symbol, process/output Eqs.
$\mathbb{N}^*/\mathbb{R}^n$	Natural numbers set $-\{0\}/n$ -dimensional Euclidean space
$\llbracket 1; n \rrbracket$	Natural numbers $\geq 1$ and $\leq n$
$(\mathbf{u}_t, \mathbf{x}_t, \mathbf{y}_t, \mathbf{z}_t)$	Input, state, output and measurement vectors at time $t$
$(M, (G, \bullet))$	(differentiable) Manifold, (Lie) Group
$(\mathbf{g}, \mathbf{e})$	Standard group and neutral elements
$\mathcal{S}^1$	Circle group
$\phi_{\mathbf{g} \in G}$	Composite transformation
$(\psi_{\mathbf{g}}, \varphi_{\mathbf{g}}, \rho_{\mathbf{g}})$	Input, state and output local actions
$\diamond$	Group multiplication operator
$\gamma$	Moving frame
$\dim(\cdot)/\text{Im}(\cdot)$	Vector space dimension/function image subset
$(\mathbf{I}, \mathbf{E}/\boldsymbol{\eta})$	Fundamental invariants, invariant output/state errors
$\partial(\cdot)/\partial \mathbf{x}_i$ or $\mathbf{v}_i$	Euclidean basis vectors
$\mathbb{E}[\cdot]/\delta_{ij}$	Mathematical expectation/Kronecker symbol
$\mathcal{X}^{(i)}$	$i^{\text{th}}$ sigma point
$\text{qr}[\cdot]$	QR factorization
$\text{cholupdate}(\cdot, \cdot, \cdot)$	Rank-1 update of Cholesky decomposition
$\mathbf{S}_k^{\mathbf{x}_1 \mathbf{x}_2}$	Square-root covariance matrix at time instant $k$
$\mathbf{P}_k^{\mathbf{x}_1 \mathbf{x}_2}$	Cross estimation error covariance matrix between $(\mathbf{x}_1, \mathbf{x}_2)$
$(\mathbf{q}, *)$	Quaternion s.t. $\mathbf{q} = (q_1 \ q_2 \ q_3 \ q_4)^T$ , Hamilton product
$\boldsymbol{\omega}_b$	Gyroscopic bias vector
$(a_s, b_s)$	Accelerometric and magnetic scaling factors

---

## 23.2 Dynamical Systems Possessing Symmetries

### 23.2.1 Theoretical Background

Defining symmetries and invariances for controllable dynamic systems represented by nonlinear state-space representations requires first to reinterpret geometrically all modeling variables. To do so, let us consider  $\Sigma$  be a continuous-



time nonlinear modeling given by:

$$\Sigma : \begin{cases} \dot{\mathbf{x}}_t = f(\mathbf{x}_t, \mathbf{u}_t) \\ \mathbf{y}_t = h(\mathbf{x}_t, \mathbf{u}_t) \end{cases} \quad (23.1)$$

In Eq. (23.1), the known input, state and output trajectory vectors, denoted by  $\mathbf{u}_t$ ,  $\mathbf{x}_t$  and  $\mathbf{y}_t$ , evolve actually through time within 3 Euclidean open sets  $\mathcal{U} \subset \mathbb{R}^m$ ,  $\mathcal{X} \subset \mathbb{R}^n$  and  $\mathcal{Y} \subset \mathbb{R}^p$  ( $(m, n, p) \in (\mathbb{N}^*)^3$ ) respectively. Applying invariant theory to system  $\Sigma$  relies then on many mathematical notions which have, for most of them, their origins in both differential geometry and group theory. Therefore, some fundamental prerequisites are first of all introduced in this section before exploiting them to establish the main results related to dynamical systems possessing symmetries. For more complete definitions see [30–32].

**Definition 1 (Topological manifold)** *A topological manifold of dimension  $r \in \mathbb{N}^*$  is a topological space which is locally homeomorphic to the Euclidean space  $\mathbb{R}^r$ .*  $\square$

Definition 1 means that if  $M$  is a topological manifold, then  $\forall \mathbf{x} \in M$ , there exists a bijective continuous function (whose inverse is also continuous) which maps every neighbourhood of  $\mathbf{x}$  to  $\mathbb{R}^r$ . It is clear by construction that the space  $M = \mathcal{U} \times \mathcal{X} \times \mathcal{Y}$  is a topological manifold (Cartesian product of Euclidean open sets). Through such homeomorphisms, called also *charts*, one can defined local coordinates of any point  $\mathbf{x}$  in  $M$ . Intuitively, searching for the symmetries or invariances of  $\Sigma$  can be viewed as a problem of determining whether two different local coordinate systems (e.g.,  $\mathbf{x}_t$ ,  $\mathbf{u}_t$  and  $\mathbf{y}_t$  transformed by rotation, translation or homothetic) define an identical dynamics  $(f, h)$  on a given manifold.

**Definition 2 (Transition map)** *Let  $\varphi_\alpha, \varphi_\beta$  be two charts of a topological manifold  $M$ . The application  $\varphi_{\alpha\beta} = \varphi_\beta \circ \varphi_\alpha^{-1}$  is called a **transition map**.*  $\square$

Definition 2 will be used to introduce the notion of differentiable manifold.

**Definition 3 (Differentiable manifold)** *A  $r$ -dimensional topological manifold  $M$  will be said **differentiable** iff its transition maps are all differentiable. Besides, it will be said of class  $C^k$  ( $k \in \mathbb{N}^*$ ) iff its transition maps are all  $k$ -times continuously differentiable.*  $\square$

Definition 3 implies that a tangent space can be attached to every point of a  $r$ -dimensional differentiable manifold. Formally, it will correspond to a  $r$ -dimensional Euclidean space which gathers all the tangent directions (i.e., vectors) at which one can tangentially pass through the point.

**Definition 4 (Tangent vector and space)** *Let  $M \subset \mathbb{R}^r$  be a real valued  $C^\infty$  manifold of dimension  $r \in \mathbb{N}^*$ . Let  $\mathbf{x}$  be a point of  $M$ . A vector  $\mathbf{v} \in \mathbb{R}^r$  will be a **tangent vector** of  $M$  at  $\mathbf{x}$  if there exists a  $C^\infty$  curve  $\vartheta : \mathbb{R} \rightarrow M$  s.t.  $\vartheta(0) = \mathbf{x}$  and  $D\vartheta(0) = \mathbf{v}$ . The set  $T_{\mathbf{x}}M = \{D\vartheta(0)/\vartheta : \mathbb{R} \rightarrow M \in C^\infty \text{ and } \vartheta(0) = \mathbf{x}\}$  corresponds to the **tangent space** of  $M$  at  $\mathbf{x}$ .*  $\square$

Definition 4 is of primary importance for introducing and defining the notion of derivative for a map between two differentiable manifolds. It will be especially true in the sequel when the group action will be introduced and applied to the dynamic system modeling of Eq. (23.1).

Among the most common manifolds, Lie groups have a central place in the application of invariant theory for dynamical systems possessing symmetries. Indeed, as it will be shown in the following, most of the applicative benchmarks used to illustrate both systems symmetries and invariant observers will highlight very well-known Lie groups.

**Definition 5 (Group)** Let  $G$  be a given set. Let  $\bullet$  be a composition law s.t.  $\bullet : G \times G \rightarrow G$ . The couple  $(G, \bullet)$  is a **group** iff the following axioms hold:

- ❶  $\forall (\mathbf{g}_1, \mathbf{g}_2) \in G^2, \mathbf{g}_1 \bullet \mathbf{g}_2 \in G$ ;
- ❷  $\forall (\mathbf{g}_1, \mathbf{g}_2, \mathbf{g}_3) \in G^3, (\mathbf{g}_1 \bullet \mathbf{g}_2) \bullet \mathbf{g}_3 = \mathbf{g}_1 \bullet (\mathbf{g}_2 \bullet \mathbf{g}_3)$ ;
- ❸  $\exists \mathbf{e} \in G, \forall \mathbf{g} \in G, \mathbf{e} \bullet \mathbf{g} = \mathbf{g} \bullet \mathbf{e} = \mathbf{g}$ ;
- ❹  $\forall \mathbf{g} \in G, \exists \mathbf{g}^{-1} \in G, \mathbf{g} \bullet \mathbf{g}^{-1} = \mathbf{g}^{-1} \bullet \mathbf{g} = \mathbf{e}$ . □

**Definition 6 (Lie groups)** A **Lie group** is a differentiable manifold that carries also the algebraic structure of a group s.t. group law (or multiplication) and its inverse correspond to  $C^\infty$  operations. □

The simplest example of Lie group is the real axis  $\mathbb{R}$  with the addition operation. In that case, 0 is the identity element and the inverse of  $x \in \mathbb{R}$  is  $-x$  which is an element of  $\mathbb{R}$ . Higher-dimensional examples can be found with the Euclidean space or both special linear  $SL(n)$  and orthogonal  $SO(n)$  groups. Thus, a Lie group structure can be associated with rotations and dilatations (*i.e.*, translations + homotheties) for instance, and these kinds of geometrical transformations will play an important role in the sequel, especially in §23.4 when  $\Sigma$  will correspond to a pure kinematics modeling based on quaternions. It is noteworthy that a Lie group of dimension  $r$  is often referred to as a  $r$ -parameter group.

At this point, introducing the notions of symmetry and invariance for dynamic systems requires the definition of group action. This group action relates each element of a given group  $G$  to a specific transformation. Therefore, it defines a set of parameterized maps which act on a given manifold  $M$ .

**Definition 7 (Group action)** Let  $(G, \bullet)$  be a Lie group with identity element  $\mathbf{e}$  and  $M$  be a  $r$ -dimensional manifold ( $r \in \mathbb{N}^*$ ). A **group action**  $\varphi_{\mathbf{g} \in G}$  on  $M$  is a regular map  $(\mathbf{g}, \mathbf{x}) \in G \times M \mapsto \varphi_{\mathbf{g}}(\mathbf{x}) \in M$  s.t.:

- ❶  $\forall \mathbf{x} \in M, \varphi_{\mathbf{e}}(\mathbf{x}) = \mathbf{x}$ ;
- ❷  $\forall (\mathbf{g}_1, \mathbf{g}_2) \in G^2, \forall \mathbf{x} \in M, \varphi_{\mathbf{g}_1}(\varphi_{\mathbf{g}_2}(\mathbf{x})) = \varphi_{\mathbf{g}_1 \bullet \mathbf{g}_2}(\mathbf{x})$ . □

It can be noticed in definition 7 that  $\varphi_{\mathbf{g}}$  is by construction a diffeomorphism on  $M$  for all  $\mathbf{g} \in G$ . The most important class of group action which plays a crucial role in the invariant theory applied to dynamical systems, such as presented below, is provided by the transformations parameterized on a given Lie group  $G$  and acting on  $G$  itself ( $\sim$  to automorphisms) by left or right multiplication.

**Example 1 (Affine group)** Consider the 2-parameter Lie group  $A(1, \mathbb{R})$  of affine transformations  $x \in \mathbb{R} \mapsto ax + b \in \mathbb{R}$  whose parametrization consist in  $(a, b) \in G = \mathbb{R}^* \times \mathbb{R}$ . The Lie group law is defined by  $(a, b) \bullet (c, d) = (ac, ad + b) \in G$  and the neutral element by  $\mathbf{e} = (1, 0)$ . Considering the group action of the affine transformations of  $x$ ,  $((a, b), x) \in G \times \mathbb{R} \mapsto ax + b \in \mathbb{R}$ , for any  $(c, d) \in G$ , axiom ② of definition 7 reads:  $\varphi_{(a,b)\bullet(c,d)}(x) = acx + ad + b$ . We can also deduce that:  $(a, b)^{-1} = (1/a, -b/a)$  (inversion map).  $\square$

**Remark 1 (Full-rank group action)** In the sequel, only full-rank group actions, i.e., s.t.  $\forall \mathbf{g} \in G$ ,  $\dim(\text{Im}(\varphi_{\mathbf{g}})) = \dim(G)$ , will be considered.  $\square$

**Remark 2 (Identification)** Moreover, in the following, only full-rank group actions from  $G$  acting on  $\mathcal{X} \subset \mathbb{R}^n$  (cf. Eq. (23.1)) s.t.  $\dim(G) = \dim(\mathcal{X}) = n \in \mathbb{N}^*$  will be considered. It implies that  $G$  and  $\mathcal{X}$  can be identified.  $\square$

From remarks 1 and 2, it follows first that the group actions will consist in Euclidean transformations parameterized by  $\mathbb{R}^n$ -state vectors  $\mathbf{x}_t$ . Besides, over the open set  $\mathcal{X} \subset \mathbb{R}^n$ , such transformations can be assimilated to left or right multiplications (denoted by  $\diamond$ ) i.e., s.t.:  $\varphi_{\mathbf{g}} : (\mathbf{g}, \mathbf{x}) \in G \times \mathcal{X} \mapsto \varphi_{\mathbf{g}}(\mathbf{x}) = \mathbf{g} \diamond \mathbf{x} \in \mathcal{X}$  (left multiplication) or  $\varphi_{\mathbf{g}} : (\mathbf{g}, \mathbf{x}) \in G \times \mathcal{X} \mapsto \varphi_{\mathbf{g}}(\mathbf{x}) = \mathbf{x} \diamond \mathbf{g}^{-1} \in \mathcal{X}$  (right multiplication).

**Definition 8 (Group orbit)** Let  $G$  be a group acting on  $\mathcal{X} \subset \mathbb{R}^n$  by a left multiplication. Let  $\mathbf{x}$  be a point of  $\mathcal{X}$ . The set  $\mathcal{O}(\mathbf{x}) = \{\mathbf{y} = \mathbf{g} \diamond \mathbf{x} / \mathbf{g} \in G\}$  defines the **group orbit** of  $\mathbf{x}$ .  $\square$

Definition 8 means that the orbit of any given point  $\mathbf{x} \in \mathcal{X}$  is a  $\mathcal{X}$ -points set to which  $\mathbf{x}$  can be moved by the elements of  $G$ .

### 23.2.2 Notion of Invariant

This paragraph makes use of the dynamic system  $\Sigma$  of Eq. (23.1). Let  $G \subset \mathbb{R}^n$  be a Lie group (as a  $n$ -dimensional Euclidean open set). We define the composite group transformation  $\phi_{\mathbf{g}}$  acting on  $M = \mathcal{U} \times \mathcal{X} \times \mathcal{Y}$  s.t.:

$$\phi_{\mathbf{g}} : (\mathbf{g}, \mathbf{u}_t, \mathbf{x}_t, \mathbf{y}_t) \in G \times M \mapsto (\psi_{\mathbf{g}}(\mathbf{u}_t), \varphi_{\mathbf{g}}(\mathbf{x}_t), \rho_{\mathbf{g}}(\mathbf{y}_t)) = (\mathbf{U}_t, \mathbf{X}_t, \mathbf{Y}_t) \in M$$

where  $\psi_{\mathbf{g}}$ ,  $\varphi_{\mathbf{g}}$  and  $\rho_{\mathbf{g}}$  are 3 group actions which share an identical parametrization group ( $G$ ) and act locally on the Euclidean open sets  $\mathcal{U}$ ,  $\mathcal{X}$  and  $\mathcal{Y}$  respectively. Based on previous remarks (see §23.2.1),  $\varphi_{\mathbf{g}}$  is equivalent here to a left multiplication  $\diamond$ .

**Definition 9 (Invariant/equivariant dynamic system)** System  $\Sigma$  of Eq. (23.1) will be said  **$G$ -invariant** if  $\exists (\psi_{\mathbf{g}}, \varphi_{\mathbf{g}})_{\mathbf{g} \in G}$ ,  $\forall (\mathbf{g}, \mathbf{u}_t, \mathbf{x}_t) \in G \times \mathcal{U} \times \mathcal{X}$ :  $f(\mathbf{X}_t, \mathbf{U}_t) = D\varphi_{\mathbf{g}}(\mathbf{x}_t) \cdot f(\mathbf{x}_t, \mathbf{u}_t)$  and  **$G$ -equivariant** if  $\exists (\rho_{\mathbf{g}})_{\mathbf{g} \in G} : G \times \mathcal{Y} \rightarrow \mathcal{Y}$ ,  $\forall (\mathbf{g}, \mathbf{u}_t, \mathbf{x}_t) \in G \times \mathcal{U} \times \mathcal{X}$ :  $h(\mathbf{X}_t, \mathbf{U}_t) = \rho_{\mathbf{g}}(h(\mathbf{x}_t, \mathbf{u}_t))$ .  $\square$

In other words, the coordinates transformations of definition 9 must be determined s.t. their respective action on input, state and output vector variables keep the whole system dynamics unchanged i.e.,  $\dot{\mathbf{X}}_t = f(\mathbf{X}_t, \mathbf{U}_t)$  and  $\mathbf{Y}_t = h(\mathbf{X}_t, \mathbf{U}_t)$ . Previous definition means that all process and output equations must remain explicitly identical when applying  $\phi_{\mathbf{g}}$ .

**Proposition 1 (Moving frame)** *Let  $\mathbf{x}_t \in \mathcal{X}$  be a point of the state open set and  $\mathbf{c} \in \text{Im}(\varphi_{\mathbf{g}})$  be an element of the image of the local diffeomorphism  $\varphi_{\mathbf{g}}$ . Then,  $\exists! \mathbf{g} \in G$ ,  $\mathbf{g} \diamond \mathbf{x}_t = \mathbf{c}$  with  $\mathbf{g} = \gamma(\mathbf{x}_t)$ . The map  $\gamma : \mathcal{X} \rightarrow G$  is called the **moving frame**.  $\square$*

Based on the Cartan moving frame method (see [30–32]), the existence of the moving frame of proposition 1 is guaranteed. Equality  $\mathbf{g} \diamond \mathbf{x}_t = \mathbf{c}$  is better known under the name of *normalization equations*. Solving these equations rely on the application of the implicit functions theorem which ensures the existence of a local solution  $\gamma$ . From a geometrical point of view, element  $\mathbf{c} = (c_1 \ c_2 \ \dots \ c_n)^T \in \mathbb{R}^n$  defines a cross section  $\mathcal{C}$  at point  $\mathbf{c}$  of the group orbit  $\mathcal{O}(\mathbf{x})$  (see Fig. 23.2). Selecting  $\mathbf{c} = \mathbf{e}$  in the normalization equations

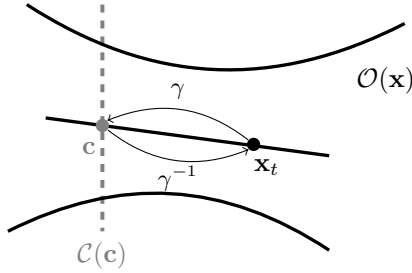

**FIGURE 23.2**  
Moving frame illustration.

permits to deduce that  $\gamma(\mathbf{x}_t) = \mathbf{x}_t^{-1}$ . The definition procedure of  $\gamma$  which consists in solving  $\mathbf{g} \diamond \mathbf{x}_t - \mathbf{e} = \mathbf{0}$  is a very useful direct method to determine the analytical expression of  $\gamma(\mathbf{x}_t)$ ,  $\forall t$  and so, the expression of system's fundamental invariants.

**Corollary 1 (Uniqueness of the moving frame)** *The uniqueness of the moving frame  $\gamma \Leftrightarrow \forall \mathbf{g} \in G, \forall \mathbf{x}_t \in \mathcal{X}, \gamma(\varphi_{\mathbf{g}}(\mathbf{x}_t)) \bullet \mathbf{g} = \gamma(\mathbf{x}_t)$ .  $\square$*

The result provided by corollary 1 will be widely exploited in section 23.3 for the definition of the different invariant state estimators.

It follows from all these theoretical results that dynamical system  $\Sigma$ 's invariants are finally defined by substituting for  $\mathbf{g}$ ,  $\gamma(\mathbf{x}_t) = \mathbf{x}_t^{-1}$  in the composite group transformation triplet  $(\phi_{\mathbf{g}})_{\mathbf{g} \in G}$ . Doing so will define a set of  $m + \mathcal{N} + p - \mathcal{N} = m + p$  fundamental invariants for  $\Sigma$  since  $\dim(G) = \dim(\mathcal{X}) = n$ .

**Definition 10 (Fundamental invariants)** *The set of the  $m + p$  fundamental invariants of system  $\Sigma$  of Eq. (23.1) is defined by:  $\mathbf{l}(\mathbf{u}_t, \mathbf{x}_t) = (\psi_{\mathbf{x}_t^{-1}}(\mathbf{u}_t), \rho_{\mathbf{x}_t^{-1}}(\mathbf{y}_t)) = (\mathbf{l}_{\mathbf{u}_t}^{\mathbf{x}_t}, h(\mathbf{e}, \mathbf{l}_{\mathbf{u}_t}^{\mathbf{x}_t}))$  where  $\mathbf{l}_{\mathbf{u}_t}^{\mathbf{x}_t}$  reads  $\psi_{\mathbf{x}_t^{-1}}(\mathbf{u}_t)$ .  $\square$*

### 23.2.3 Academic Example

We consider in this subsection the case of a nonholonomic car (cf. Fig 23.3). This system is parameterized s.t.: -  $\delta$  is the angle between front wheels and

car axis;  $-\theta$  is the angle formed by the  $(Ox)$  axis and car axis;  $-(x, y)$  are the coordinates of the middle of the rear axle in the reference frame. Moreover,  $u$  is the car speed modulus and  $v = \tan(\delta)/L$ . Making explicit the speeds composition rule, the car dynamics reads:

$$\Sigma : \begin{cases} \dot{\mathbf{x}}_t = \begin{pmatrix} \dot{x} \\ \dot{y} \\ \dot{\theta} \end{pmatrix} = \begin{pmatrix} u \cos(\theta) \\ u \sin(\theta) \\ uv \end{pmatrix} = f(\mathbf{x}_t, \mathbf{u}_t = (u \ v)^T) \\ \mathbf{y}_t = (x \ y)^T = h(\mathbf{x}_t, \mathbf{u}_t) \end{cases} \quad (23.2)$$

One can easily check that car's dynamics is independent of both frame origin and orientation. This implies that  $\Sigma$  is invariant by both translation and rotation transformations *i.e.*, invariant under the action of the planar Special Euclidean group  $SE(2)$  describing roto-translations in  $2D$ -Euclidean space. The state space  $\mathcal{X} = \mathbb{R}^2 \times \mathcal{S}^1$  (where  $\mathcal{S}^1$  designates the circle) coincides

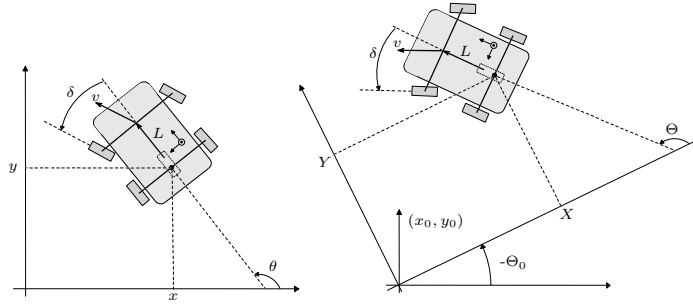

**FIGURE 23.3**

Academic example of the nonholonomic car.  
(left: standard parametrization - right: group action effect).

topologically with  $SE(2)$  as illustrated by Fig. 23.4. The trajectory  $T(t)$  corresponds to the real path followed by the car but projected in  $SE(2)$ . If we identify the reference Lie group  $G$ , used to parameterize the group actions, to  $\mathbb{R}^2 \times \mathcal{S}^1$ , it follows that the process dynamics of Eq. (23.2) will be invariant when applying the input and state transformations  $\psi_{\mathbf{g}_0}(\mathbf{u}_t)$  and  $\varphi_{\mathbf{g}_0}(\mathbf{x}_t)$  defined by  $(\mathbf{g}_0 = (x_0 \ y_0 \ \theta_0)^T)$ :

$$\psi_{\mathbf{g}_0}(\mathbf{u}_t) = \begin{pmatrix} u \\ v \end{pmatrix} = \begin{pmatrix} U \\ V \end{pmatrix}, \quad \varphi_{\mathbf{g}_0}(\mathbf{x}_t) = \begin{pmatrix} x \cos \theta_0 - y \sin \theta_0 + x_0 \\ x \sin \theta_0 + y \cos \theta_0 + y_0 \\ \theta + \theta_0 \end{pmatrix} = \begin{pmatrix} X \\ Y \\ \Theta \end{pmatrix}$$

System  $\Sigma$  is indeed invariant by these 2 transformations since for instance:

$$\begin{aligned} \dot{X} &= \overbrace{(x \cos \theta_0 - y \sin \theta_0 + x_0)}^{\dot{x} \cos \theta_0 - \dot{y} \sin \theta_0} = \dot{x} \cos \theta_0 - \dot{y} \sin \theta_0 = u(\cos \theta \cos \theta_0 - \sin \theta \sin \theta_0) \\ &= u \cos(\theta + \theta_0) = U \cos \Theta \quad \square \end{aligned}$$

Moreover, system's output equation appears also  $G$ -compatible if we consider the local transformation  $\rho_{\mathbf{g}_0}(\mathbf{y}_t)$  defined by:

$$\rho_{\mathbf{g}_0}(\mathbf{y}_t) = \begin{pmatrix} x \cos \theta_0 - y \sin \theta_0 + x_0 \\ x \sin \theta_0 + y \cos \theta_0 + y_0 \end{pmatrix} = h(\varphi_{\mathbf{g}_0}(\mathbf{x}_t), \psi_{\mathbf{g}_0}(\mathbf{u}_t)) = h(X, Y)$$

The composite group transformation  $\phi_{\mathbf{g}_0} = (\psi_{\mathbf{g}_0}, \varphi_{\mathbf{g}_0}, \rho_{\mathbf{g}_0})$  defined above is s.t.  $\dim(G) = \dim(\mathcal{X}) = n = 3$  as mentioned by remark 2. Since  $\dim(\text{Im}(\varphi_{\mathbf{g}_0})) = \dim(G) = 3$  (cf. remark 1), the identification of  $G$  to  $\mathcal{X}$  allows to deduce easily the inverse element of any  $\mathbf{g}_0 \in G$ , especially the group element which moves any  $\mathbf{x}_t \in \mathcal{X}$  to the neutral element  $\mathbf{e} = \mathbf{0}$ . Therefore, the moving frame is given by:  $\mathbf{x}_t^{-1} = -((x \cos \theta + y \sin \theta) \ (-x \sin \theta + y \cos \theta) \ \theta)^T$ . Indeed, the normalization equations read:

$$\varphi_{\mathbf{g}_0}(\mathbf{x}_t) = \begin{pmatrix} x \cos \theta_0 - y \sin \theta_0 + x_0 \\ x \sin \theta_0 + y \cos \theta_0 + y_0 \\ \theta + \theta_0 \end{pmatrix} = \mathbf{e} = \begin{pmatrix} 0 \\ 0 \\ 0 \end{pmatrix} \Rightarrow \begin{cases} x_0 = -x \cos \theta - y \sin \theta \\ y_0 = x \sin \theta - y \cos \theta \\ \theta_0 = -\theta \end{cases}$$

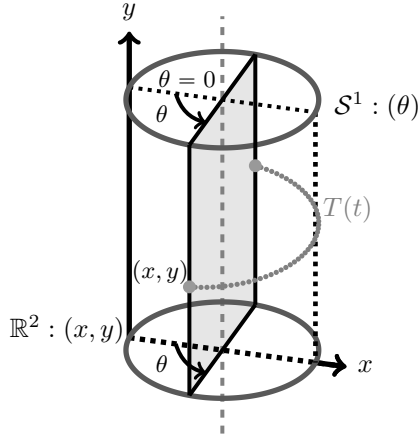

**FIGURE 23.4**  
 $SE(2)$ -topological equivalence of the state space  $\mathcal{X} = \mathbb{R}^2 \times \mathcal{S}^1$ .

## 23.3 Optimal Invariant Nonlinear State Estimation

### 23.3.1 Invariant Observer

Considering a continuous nonlinear  $G$ -invariant/equivariant dynamical system modeling  $\Sigma$  such as in Eq. (23.1), the general form of a nonlinear continuous-

time symmetry-preserving state observer will be defined s.t.:

$$\dot{\hat{\mathbf{x}}}_t = f(\hat{\mathbf{x}}_t, \mathbf{u}_t) + \sum_{i=1}^n K_i[\mathbf{l}(\mathbf{u}_t, \hat{\mathbf{x}}_t), \mathbf{z}_t] \cdot \mathbf{w}_i(\hat{\mathbf{x}}_t) \quad (23.3)$$

In (23.3),  $\hat{\mathbf{x}}$  refers to the estimated state vector.  $\mathbf{z}$  is the measurements vector. All the measurements are assumed to be corrupted by noises and some of them are subject to bias-type errors. Both assumptions on noises and additive state variables will permit to account for these disturbances for invariant nonlinear state estimation. Eq. (23.3) follows the standard expression of many nonlinear state estimators (such as Luenberger observers or Kalman filters) in which a model-based prediction, calculated here from G-invariant process equations, is corrected to produce estimation time derivative. For invariant nonlinear state estimation however, correction must be constructed s.t. Eq. (23.3) will be also G-invariant. In other words, observer's dynamics must verify similar invariance properties w.r.t. the original system. Thus, in formulation (23.3), predicted state derivative correction appears expressed as the linear combination of the  $n$  invariant basis vectors  $\mathbf{w}_i(\hat{\mathbf{x}}_t)$  with associated scalar weighting coefficients  $K_i[\mathbf{l}(\mathbf{u}_t, \hat{\mathbf{x}}_t), \mathbf{z}_t]$ . Each  $K_i$  factor expression shows that the observer gain depends nonlinearly on system fundamental invariants  $\mathbf{l}$  which read, based on previous underlying assumptions:

$$\begin{aligned} \mathbf{l}(\mathbf{u}_t, \hat{\mathbf{x}}_t) &= (\psi_{\hat{\mathbf{x}}_t^{-1}}(\mathbf{u}_t), \varphi_{\hat{\mathbf{x}}_t^{-1}}(\hat{\mathbf{x}}_t), \rho_{\hat{\mathbf{x}}_t^{-1}}(\hat{\mathbf{y}}_t)) \\ &= (\mathbf{l}_{\mathbf{u}_t}^{\hat{\mathbf{x}}_t}, \mathbf{e}, \rho_{\hat{\mathbf{x}}_t^{-1}}(h(\hat{\mathbf{x}}_t, \mathbf{u}_t))) \\ &\Leftrightarrow (\mathbf{l}_{\mathbf{u}_t}^{\hat{\mathbf{x}}_t}, h(\varphi_{\hat{\mathbf{x}}_t^{-1}}(\hat{\mathbf{x}}_t), \psi_{\hat{\mathbf{x}}_t^{-1}}(\mathbf{u}_t))) \\ &= (\mathbf{l}_{\mathbf{u}_t}^{\hat{\mathbf{x}}_t}, h(\mathbf{e}, \mathbf{l}_{\mathbf{u}_t}^{\hat{\mathbf{x}}_t})) \in \mathcal{U} \times \mathcal{Y} \subset \mathbb{R}^{m+p} \end{aligned} \quad (23.4)$$

In (23.4),  $\mathbf{e}$  corresponds to the neutral element associated with the local state transformation  $\varphi_{\mathbf{g} \in \mathbf{G}}$  and can be viewed as a constant quantity. Eq. (23.4) defines a set of  $m+p$  invariants which are functionally independent. In practice, the correction term will depend on these latter through the introduction of an invariant innovation vector, also called invariant output error, denoted by  $\mathbf{E}$  and expressed s.t.:

$$\mathbf{E} = \rho_{\hat{\mathbf{x}}_t^{-1}}(\hat{\mathbf{y}}_t) - \rho_{\hat{\mathbf{x}}_t^{-1}}(\mathbf{z}_t) = h(\mathbf{e}, \mathbf{l}_{\mathbf{u}_t}^{\hat{\mathbf{x}}_t}) - \rho_{\hat{\mathbf{x}}_t^{-1}}(\mathbf{z}_t) = \mathbf{E}(\hat{\mathbf{x}}_t, \mathbf{l}_{\mathbf{u}_t}^{\hat{\mathbf{x}}_t}, \mathbf{z}_t) \quad (23.5)$$

This invariant output error connects the measurements to their estimated values through the local transformation  $\rho$ , or equivalently, connects the image by  $\rho$  of  $\mathbf{z}_t$  to the one by  $h$  of both system neutral element and input invariants. Therefore, Eq. (23.3) can be rewritten s.t.:

$$\dot{\hat{\mathbf{x}}}_t = f(\hat{\mathbf{x}}_t, \mathbf{u}_t) + \sum_{i=1}^n K_i[\mathbf{E}(\hat{\mathbf{x}}_t, \mathbf{l}_{\mathbf{u}_t}^{\hat{\mathbf{x}}_t}, \mathbf{z}_t)] \cdot \mathbf{w}_i(\hat{\mathbf{x}}_t) \quad (23.6)$$

$(\mathbf{w}_i(\hat{\mathbf{x}}_t))_{i \in \llbracket 1; n \rrbracket}$  forms a G-invariant frame which projects each correction term on the G-invariant tangent state space  $T_{\hat{\mathbf{x}}_t} \mathcal{X}$  defined by  $f(\hat{\mathbf{x}}_t, \mathbf{u}_t)$ . They are

defined s.t.:

$$\forall i \in \llbracket 1; n \rrbracket, \mathbf{w}_i(\hat{\mathbf{x}}_t) = \left[ D\varphi_{\hat{\mathbf{x}}_t^{-1}}(\hat{\mathbf{x}}_t) \right]^{-1} \cdot \partial(\cdot)/\partial \mathbf{x}_i \quad (23.7)$$

In (23.7),  $\partial(\cdot)/\partial \mathbf{x}_i$  refers to the  $i^{\text{th}}$  canonical basis vector of  $\mathbb{R}^n$ . The invariant frame computation requires the inversion of the Jacobian matrix  $D\varphi_{\hat{\mathbf{x}}_t^{-1}}$  which can be carried out analytically and easily in many practical applications. This calculation is however non-systematic since the composite transformation  $\phi_{\mathbf{g} \in \mathbf{G}}$  is proper to each system modeling. The observer dynamics in Eq. (23.6) is clearly G-invariant. Indeed, by posing  $\dot{\hat{\mathbf{x}}}_t = F(\hat{\mathbf{x}}_t, \mathbf{u}_t, \mathbf{z}_t)$ , we have  $\forall \mathbf{g} \in \mathbf{G}$ :

$$F(\varphi_{\mathbf{g}}(\hat{\mathbf{x}}_t), \psi_{\mathbf{g}}(\mathbf{u}_t), \rho_{\mathbf{g}}(\mathbf{z}_t)) = D\varphi_{\mathbf{g}}(\hat{\mathbf{x}}_t) \cdot F(\hat{\mathbf{x}}_t, \mathbf{u}_t, \mathbf{z}_t) \quad (23.8)$$

since (see [18–20] for more calculation details):

- $f$  (G-invariant) verifies  $f(\varphi_{\mathbf{g}}(\hat{\mathbf{x}}_t), \psi_{\mathbf{g}}(\mathbf{u}_t)) = D\varphi_{\mathbf{g}}(\hat{\mathbf{x}}_t) \cdot f(\hat{\mathbf{x}}_t, \mathbf{u}_t)$ ;
- $\mathbf{E}$  is invariant by construction *i.e.*,  $\mathbf{E}(\varphi_{\mathbf{g}}(\hat{\mathbf{x}}_t), \mathbf{l}_{\psi_{\mathbf{g}}(\mathbf{u}_t)}^{\varphi_{\mathbf{g}}(\hat{\mathbf{x}}_t)}, \rho_{\mathbf{g}}(\mathbf{z}_t)) = \mathbf{E}(\hat{\mathbf{x}}_t, \mathbf{l}_{\mathbf{u}_t}^{\hat{\mathbf{x}}_t}, \mathbf{z}_t)$ ;
- and  $\forall i \in \llbracket 1; n \rrbracket, \mathbf{w}_i(\varphi_{\mathbf{g}}(\hat{\mathbf{x}}_t)) = D\varphi_{\mathbf{g}}(\hat{\mathbf{x}}_t) \cdot \mathbf{w}_i(\hat{\mathbf{x}}_t)$  (due to the unicity of  $\gamma$ ).

Similarly to  $\mathbf{E}$ , the convergence analysis (*i.e.*,  $\hat{\mathbf{x}}_t \mapsto \mathbf{x}_t$ ) of  $F$  in Eq. (23.6) appears facilitated when an invariant state estimation error, denoted by  $\boldsymbol{\eta}(\mathbf{x}_t, \hat{\mathbf{x}}_t)$ , is considered instead of a linear system error  $\mathbf{x}_t - \hat{\mathbf{x}}_t$ . This error reads:

$$\boldsymbol{\eta}(\mathbf{x}_t, \hat{\mathbf{x}}_t) = \varphi_{\hat{\mathbf{x}}_t^{-1}}(\mathbf{x}_t) - \varphi_{\hat{\mathbf{x}}_t^{-1}}(\hat{\mathbf{x}}_t) = \hat{\mathbf{x}}_t^{-1} \diamond \mathbf{x}_t - \mathbf{e} \quad (23.9)$$

By definition,  $\boldsymbol{\eta}$  verifies  $\forall \mathbf{g} \in \mathbf{G}, \boldsymbol{\eta}(\varphi_{\mathbf{g}}(\mathbf{x}_t), \varphi_{\mathbf{g}}(\hat{\mathbf{x}}_t)) = \boldsymbol{\eta}(\mathbf{x}_t, \hat{\mathbf{x}}_t)$  and its dynamics through time is driven by an autonomous differential equation s.t.:

$$\dot{\boldsymbol{\eta}}(\mathbf{x}_t, \hat{\mathbf{x}}_t) = \Upsilon(\boldsymbol{\eta}(\mathbf{x}_t, \hat{\mathbf{x}}_t), \mathbf{l}_{\mathbf{u}_t}^{\hat{\mathbf{x}}_t}) \quad (\text{with } \Upsilon \text{ smooth function}) \quad (23.10)$$

This result shows that the invariant state estimation error depends on system's trajectory  $t \mapsto (\mathbf{x}_t, \mathbf{u}_t)$  through its fundamental invariants. It is noteworthy that when  $\forall t, \mathbf{l}_{\mathbf{u}_t}^{\hat{\mathbf{x}}_t} \equiv I(\mathbf{u}_t)$  (with  $I$  continuous function of  $\mathbf{u}_t$ ),  $\dot{\boldsymbol{\eta}}$  is independent of the followed state trajectory  $\mathbf{x}_t$ , which increases *de facto* the convergence domain of  $F$ .

Followingly, when no error impairs system's observation equations (*i.e.*,  $\hat{\mathbf{y}}_t = h(\hat{\mathbf{x}}_t, \mathbf{u}_t) = \mathbf{z}(t)$ ), it follows that  $\mathbf{E} := \mathbf{0}$  by definition. In that peculiar case, each  $\mathbf{K}_i$  weight must satisfy:

$$\forall i \in \llbracket 1; n \rrbracket, \mathbf{K}_i[\mathbf{E}(\hat{\mathbf{x}}_t, \mathbf{l}_{\mathbf{u}_t}^{\hat{\mathbf{x}}_t}, \hat{\mathbf{y}}_t) = \mathbf{0}] = 0 \quad (23.11)$$

in order to confer to the invariant observer a consistent behaviour. Hence, a linearized version w.r.t.  $\mathbf{E}$  of the continuous-time symmetry-preserving invariant state observer (23.6) can be derived s.t.:

$$\dot{\hat{\mathbf{x}}}_t \cong f(\hat{\mathbf{x}}_t, \mathbf{u}_t) + \sum_{i=1}^n \left\{ \bar{\mathbf{K}}_i[\mathbf{E}] \times \mathbf{E}(\hat{\mathbf{x}}_t, \mathbf{l}_{\mathbf{u}_t}^{\hat{\mathbf{x}}_t}, \mathbf{z}_t) \right\} \cdot \mathbf{w}_i(\hat{\mathbf{x}}_t) \quad (23.12)$$



by expanding in Taylor's series function  $K_i[\mathbf{E}(\hat{\mathbf{x}}_t, \mathbf{I}_{\mathbf{u}_t}^{\hat{\mathbf{x}}_t}, \mathbf{z}_t)]$  at first order. In (23.12),  $\forall i \in \llbracket 1; n \rrbracket$ ,  $\bar{\mathbf{K}}_i[\mathbf{E}] = \bar{\mathbf{K}}_i[\mathbf{E}(\hat{\mathbf{x}}_t, \mathbf{I}_{\mathbf{u}_t}^{\hat{\mathbf{x}}_t}, \mathbf{z}_t)] \in \mathcal{M}_{1 \times p}(\mathbb{R})$ . At this point, the design of the invariant observer described in Eq. (23.12) relies on the determination of the  $n$  gain vector(s)  $\bar{\mathbf{K}}_i[\mathbf{E}]$ . For numerous applications, the invariant observer gain(s) calculation can be addressed *ad hoc* by first, investigating the observer detailed nonlinear equations, and then, by choosing gain value(s) which will meet some predefined requirements in terms of: - convergence (guarantee and domain); - decoupling purposes; - subsystems settling time/damping ratio; - etc. This calculation can also be carried out with more genericity by adapting well-proven optimal filtering techniques. This has led to the development of the so-called **Invariant Unscented Kalman Filter (IUKF)** from Eq. (23.12). The **IUKF** gain vector(s) computation resumes the main steps of the standard **UKF** algorithm (in its square root computational version), except that  $\bar{\mathbf{K}}_i[\mathbf{E}]$  will not be adapted from both linear state and output errors but from their invariant counterparts ( $\boldsymbol{\eta}$  and  $\mathbf{E}$ ). § 23.3.2 details this new approach to derive optimal invariant filters for nonlinear state estimation.

### 23.3.2 Invariant UKF: Principles and Design

The **IUKF** relies on the basic theoretical principles developed by Julier and Uhlmann at the beginning of 2000s (see [23]) which have been since widely applied to various nonlinear state estimation problems (cf. [21, 22]). The standard **UKF** algorithm exploits a deterministic sampling technique, known as the unscented transform (see [24]), in order to pick a minimal set of sample points, also called *sigma* points, around the mean state vector. These latter are then propagated through the nonlinear state  $f$  and output  $h$  equations, from which both estimated mean and covariance are then recovered. The resulting filter captures the true mean and covariance with more accuracy than any other Kalman filtering techniques. In addition, this method removes the requirement to explicitly calculate the Jacobian matrices  $\partial f / \partial \mathbf{x}$  and  $\partial h / \partial \mathbf{x}$  w.r.t. standard **Extended Kalman Filter (EKF)**, which can be a difficult task in itself for complex systems. Besides, to improve its computational efficiency the standard **UKF** algorithm can be derived in several factorized versions (cf. [25, 26]). In the sequel, the square-root formulation will be considered.

The developed **IUKF** algorithm permits to design a nonlinear discrete-time invariant state observer from the discretized modeling  $\Sigma_d$  described by:

$$\forall k \in \mathbb{N}, \Sigma_d : \begin{cases} \mathbf{x}_{k+1} = f_d(\mathbf{x}_k, \mathbf{u}_k) + \mathbf{v}_k \\ \mathbf{y}_k = h_d(\mathbf{x}_k, \mathbf{u}_k) + \mathbf{w}_k \end{cases} \text{ with: } \forall (i, j) \in \mathbb{N}^2 \begin{cases} \mathbf{E}[\mathbf{v}_i] = \mathbf{E}[\mathbf{w}_j] = \mathbf{0} \\ \mathbf{E}[\mathbf{v}_i \mathbf{w}_j^T] = \mathbf{0} \\ \mathbf{E}[\mathbf{v}_i \mathbf{v}_j^T] = \delta_{ij} \mathbf{V}_i \\ \mathbf{E}[\mathbf{w}_i \mathbf{w}_j^T] = \delta_{ij} \mathbf{W}_i \end{cases}$$

Integer  $k$  corresponds to the time index.  $\mathbf{v}_k$  (resp.  $\mathbf{w}_k$ ) refers to the discrete Gaussian process (resp. observation) noise.  $\delta_{ij}$  is the Kronecker symbol. The estimation process starts with the computation of the  $2n + 1$  *sigma points*,

denoted by  $\mathcal{X}$ , s.t.  $\mathcal{X}_{k|k}^{(0)} = \hat{\mathbf{x}}_{k|k}$ . This calculation is based on the scaled unscented transformation (see [24]) which scatters the points according to the estimated state error covariance matrix  $\mathbf{P}_{k|k}^{\mathbf{xx}} = \mathbf{S}_{k|k}^{\mathbf{xx}} \cdot (\mathbf{S}_{k|k}^{\mathbf{xx}})^T$  at time  $k$ , and provides also two series of  $2n + 1$  scalar weighting factors, denoted by  $\{W_m^{(i)}\}$  and  $\{W_c^{(i)}\}$  ( $i \in \llbracket 0; 2n \rrbracket$ ), for mean and covariance approximations. During prediction step, all *sigma points* are then propagated through both G-invariant  $f_d$  and G-equivariant  $h_d$  in order to deduce vectors  $\hat{\mathbf{x}}_{k+1|k}$  and  $\hat{\mathbf{y}}_{k+1|k}$ , but also covariance matrices  $\mathbf{S}_{k+1|k}^{\mathbf{xx}}$ ,  $\mathbf{S}_{k+1|k}^{\mathbf{yy}}$  and  $\mathbf{P}_{k+1|k}^{\mathbf{xy}}$  associated with both state and output invariant errors s.t.:

$$\begin{aligned}
 \textcircled{1} \quad & \forall i \in \llbracket 0; 2n \rrbracket, \quad \mathcal{X}_{k+1|k}^{(i)} = f_d(\mathcal{X}_{k|k}^{(i)}, \mathbf{u}_k) \Rightarrow \hat{\mathbf{x}}_{k+1|k} = \sum_{i=0}^{2n} W_m^{(i)} \mathcal{X}_{k+1|k}^{(i)} \\
 \textcircled{2} \quad & \mathbf{S}_{k+1|k}^{\mathbf{xx}} = \begin{cases} \textcircled{1} \text{ qr} \left[ \sqrt{W_c^{(1)}} \left( \boldsymbol{\eta}(\hat{\mathbf{x}}_{k+1|k}, \mathcal{X}_{k+1|k}^{(1)}) \dots \boldsymbol{\eta}(\hat{\mathbf{x}}_{k+1|k}, \mathcal{X}_{k+1|k}^{(2n)}) \right) \mathbf{V}_k^{1/2} \right] \\ \textcircled{2} \text{ cholupdate} \left( \mathbf{S}_{k+1|k}^{\mathbf{xx}}, \boldsymbol{\eta}(\hat{\mathbf{x}}_{k+1|k}, \mathcal{X}_{k+1|k}^{(0)}), W_c^{(0)} \right) \end{cases} \\
 \textcircled{3} \quad & \forall i \in \llbracket 0; 2n \rrbracket, \quad \hat{\mathbf{y}}_{k+1|k}^{(i)} = h_d(\mathcal{X}_{k+1|k}^{(i)}, \mathbf{u}_k) \Rightarrow \hat{\mathbf{y}}_{k+1|k} = \sum_{i=0}^{2n} W_m^{(i)} \hat{\mathbf{y}}_{k+1|k}^{(i)} \\
 \textcircled{4} \quad & \mathbf{S}_{k+1|k}^{\mathbf{yy}} = \begin{cases} \textcircled{1} \text{ qr} \left[ \sqrt{W_c^{(1)}} \left( \mathbf{E}(\mathcal{X}_{k+1|k}^{(1)}, \mathbf{l}_{\mathbf{u}_k}^{\mathbf{x}_{k+1|k}^{(1)}}, \hat{\mathbf{y}}_{k+1|k}) \dots \right. \right. \\ \quad \left. \left. \mathbf{E}(\mathcal{X}_{k+1|k}^{(2n)}, \mathbf{l}_{\mathbf{u}_k}^{\mathbf{x}_{k+1|k}^{(2n)}}, \hat{\mathbf{y}}_{k+1|k}) \right) \mathbf{W}_k^{1/2} \right] \\ \textcircled{2} \text{ cholupdate} \left( \mathbf{S}_{k+1|k}^{\mathbf{yy}}, \mathbf{E}(\mathcal{X}_{k+1|k}^{(0)}, \mathbf{l}_{\mathbf{u}_k}^{\mathbf{x}_{k+1|k}^{(0)}}, \hat{\mathbf{y}}_{k+1|k}), W_c^{(0)} \right) \end{cases} \\
 \textcircled{5} \quad & \mathbf{P}_{k+1|k}^{\mathbf{xy}} = \sum_{i=0}^{2n} W_c^{(i)} \boldsymbol{\eta}(\mathcal{X}_{k+1|k}^{(i)}, \hat{\mathbf{x}}_{k+1|k}) \mathbf{E}^T(\mathcal{X}_{k+1|k}^{(i)}, \mathbf{l}_{\mathbf{u}_k}^{\mathbf{x}_{k+1|k}^{(i)}}, \hat{\mathbf{y}}_{k+1|k})
 \end{aligned}$$

Previous matricial computations rely on both QR decomposition and rank 1 update to Cholesky factorization (`cholupdate`). Local transformations  $(\psi_{\mathbf{g}}, \varphi_{\mathbf{g}}, \rho_{\mathbf{g}})$  are here defined as for system  $\Sigma_d$ . In this formulation, state, output and crossed error covariances are now defined from system modeling invariants. It is clear by transitivity that these matricial quantities are left unchanged by the composite transformation  $\phi_{\mathbf{g} \in \mathbf{G}} = (\psi_{\mathbf{g}}, \varphi_{\mathbf{g}}, \rho_{\mathbf{g}})$ . It follows that correction step reads:

$$\begin{aligned}
 \textcircled{6} \quad & \forall i \in \llbracket 1; n \rrbracket, \quad \bar{\mathbf{K}}_i[\mathbf{E}] = i^{th} \text{ row of } \mathbf{K} = (\mathbf{P}_{k+1|k}^{\mathbf{xy}} / (\mathbf{S}_{k+1|k}^{\mathbf{yy}})^T) / \mathbf{S}_{k+1|k}^{\mathbf{yy}} \\
 \textcircled{7} \quad & F : \hat{\mathbf{x}}_{k+1|k+1} = \hat{\mathbf{x}}_{k+1|k} + \sum_{i=1}^n \bar{\mathbf{K}}_i[\mathbf{E}] \times \mathbf{E}(\hat{\mathbf{x}}_{k+1|k}, \mathbf{l}_{\mathbf{u}_k}^{\hat{\mathbf{x}}_{k+1|k}}, \mathbf{z}_{k+1}) \cdot \mathbf{w}_i(\hat{\mathbf{x}}_{k+1|k}) \\
 \textcircled{8} \quad & \mathbf{S}_{k+1|k+1}^{\mathbf{xx}} = \text{cholupdate} \left( \mathbf{S}_{k+1|k}^{\mathbf{xx}}, \mathbf{K} \mathbf{S}_{k+1|k}^{\mathbf{yy}}, -1 \right)
 \end{aligned}$$

Starting from initial values  $\hat{\mathbf{x}}_0 = \mathbf{E}[\mathbf{x}_0]$ ,  $\mathbf{P}_0^{\mathbf{xx}} = \mathbf{E}[\boldsymbol{\eta}(\mathbf{x}_0, \hat{\mathbf{x}}_0) \boldsymbol{\eta}^T(\mathbf{x}_0, \hat{\mathbf{x}}_0)]$  and iterating on  $k$  previous two-steps procedure (prediction/correction) permit to design an invariant nonlinear state observer in discrete time. When any given permanent trajectory  $t \mapsto (\mathbf{x}_p(t), \mathbf{u}_p(t))$  is followed (*i.e.*, s.t.  $\forall t, \mathbf{l}_{\mathbf{u}_p}^{\mathbf{x}_p}(t) = \bar{\mathbf{I}}$ ),

1<sup>st</sup> order approximation of Eq. (23.10) shows that if  $\mathbf{K}$  is also determined s.t. matrix  $\partial\Upsilon(0, \bar{\mathbf{1}})/\partial\boldsymbol{\eta}$  is stable, then observer  $F$  will converge locally around  $(\mathbf{x}_p(t), \mathbf{u}_p(t))$ . Reuse of system modeling invariances within invariant observer design also guarantees that it will converge for any group action image  $(\psi_{\mathbf{g}}(\mathbf{u}_p(t)), \varphi_{\mathbf{g}}(\mathbf{x}_p(t)))_{\mathbf{g} \in \mathbf{G}}$ . This property is remarkable especially for dynamical systems described by kinematics relationships whose dynamics is invariant by translation and rotation movements. This latter point will be illustrated in section 23.4, and more especially in §23.4.2 with the **AHRS** example.

---

## 23.4 Benchmark and Application

### 23.4.1 Dynamic System Modeling

This subsection details the generic modeling used to tackle and solve the issue of estimating some key flight variables (attitude-orientation, angle rates, etc.) of mini-UAVs fitted out with an **Attitude and Heading Reference System (AHRS)**. UAVs dynamics representation corresponds here to a pure quaternional kinematics modeling (whose related quaternion will be denoted by  $\mathbf{q}$ ), supplemented by additive state variables which represent low frequency sensors' imperfections (such as slowly varying biases). Thereby, we consider:

$$\Sigma : \left\{ \dot{\mathbf{x}}_t = \begin{pmatrix} \dot{\mathbf{q}} = \mathbf{q} * (\boldsymbol{\omega}_m - \boldsymbol{\omega}_b)/2 \\ \dot{\boldsymbol{\omega}}_b = \mathbf{0} \\ \dot{a}_s = 0 \\ \dot{b}_s = 0 \end{pmatrix}, \mathbf{y}_t = \begin{pmatrix} \mathbf{y}_A = a_s \mathbf{q}^{-1} * \mathbf{A} * \mathbf{q} \\ \mathbf{y}_B = b_s \mathbf{q}^{-1} * \mathbf{B} * \mathbf{q} \end{pmatrix} \right. \quad (23.13)$$

where  $\boldsymbol{\omega}_m$  is seen as an imperfect and noisy, but known, measured input, like  $\mathbf{B}$ . Constant  $\mathbf{A} = (0 \ 0 \ g)^T$  refers to the local Earth's gravity vector. Nonlinear state space representation of Eq. (23.13) can be described in a compact form s.t.  $\dot{\mathbf{x}}_t = f(\mathbf{x}_t, \mathbf{u}_t)$  and  $\mathbf{y}_t = h(\mathbf{x}_t, \mathbf{u}_t)$  where  $\mathbf{u}_t = \boldsymbol{\omega}_m$ ,  $\mathbf{x}_t = (\mathbf{q}^T \ \boldsymbol{\omega}_b^T \ a_s \ b_s)^T$  and  $\mathbf{y}_t = (\mathbf{y}_A^T \ \mathbf{y}_B^T)^T$  are the input, state and output vectors respectively. The nonlinear state estimation problem makes use of 3 triaxial sensors which deliver a total of 9 scalar measurement signals:  $\blacktriangleright$  3 *magnetometers* permit to obtain a local measurement of Earth's magnetic field, which is known constant and expressed in the body-fixed frame s.t. vector  $\mathbf{y}_B = \mathbf{q}^{-1} * \mathbf{B} * \mathbf{q}$  (where  $\mathbf{B} = (B_x \ B_y \ B_z)^T$ ) can be considered as an output of the observation equations;  $\blacktriangleright$  3 *gyroscopes* produce the measurements associated with the instantaneous angular rates gathered in  $\boldsymbol{\omega}_m \in \mathbb{R}^3$  s.t.  $\boldsymbol{\omega}_m = (\omega_{mx} \ \omega_{my} \ \omega_{mz})^T$ ;  $\blacktriangleright$  and 3 *accelerometers* provide the measured output signals corresponding to the specific acceleration, denoted by  $\mathbf{a}_m \in \mathbb{R}^3$  with  $\mathbf{a}_m = (a_{mx} \ a_{my} \ a_{mz})^T$ . As no velocity and position information is available (no **GPS**, nor Pitot data fusion), this **AHRS** is often qualified as *non-aided*. Thus, to keep the whole nonlinear state representation observable given these available measurements, the

assumption that the linear acceleration  $\dot{\mathbf{V}}$  remains negligible is also made *i.e.*,  $\dot{\mathbf{V}} = \mathbf{0}$ . Consequently, the specific acceleration vector, expressed in the body-fixed frame, can be approximated by  $-a_s \mathbf{q}^{-1} * \mathbf{A} * \mathbf{q} = -\mathbf{y}_A$  and compared with its corresponding imperfect and noisy measurement  $\mathbf{a}_m$ . Taking into account the maximum number of sensors' imperfections (such as low frequency disturbances) within the estimation process requires the introduction of several additive state variables. A 1<sup>st</sup>-order observability analysis (see [20] for more calculation details) shows that until 6 additional unknown constants can be estimated without introducing inobservability. Thus, the choice of considering an additive constant bias vector  $\boldsymbol{\omega}_b$  on the angular rates vector measurement  $\boldsymbol{\omega}_m$  has been made. Then, only 2 (of possible 3) additional parameters have been introduced. Doing so allows to rely not too much on the possibly perturbed magnetic field within the estimation process of  $\mathbf{y}_A$ . These 2 additive variables correspond to positive constant scaling factors, denoted by  $a_s$  and  $b_s$ , which adjust and correct the predicted outputs  $\mathbf{y}_A$  and  $\mathbf{y}_B$  respectively. All these sensor imperfections are modeled as pseudo-Gaussian random walks which can be physically interpreted as slowly varying parameters.

### 23.4.2 IUKF Estimator Design

Considering the expressions of system modeling given in Eq. (23.13) and the Lie-group  $G$  defined s.t.  $G = \mathbb{H}_1 \times \mathbb{R}^5$  (where  $\mathbb{H}_1$  designates the differentiable manifold composed of quaternions with unit norm which is homeomorphic to  $\mathbb{R}^3$ ), the following input, state and output transformations prove that system modeling  $\Sigma$  is both  $G$ -invariant and  $G$ -equivariant (see definition 9). These latter read  $\forall \mathbf{g}_0 = (\mathbf{q}_0^T \ \boldsymbol{\omega}_0^T \ a_0 \ b_0)^T \in G$  and  $\forall (\mathbf{u}_t, \mathbf{x}_t, \mathbf{y}_t) \in \mathcal{U} \times \mathcal{X} \times \mathcal{Y}$ :

$$\begin{cases} \psi_{\mathbf{g}_0}(\mathbf{u}_t) &= \mathbf{q}_0^{-1} * \boldsymbol{\omega}_m * \mathbf{q}_0 + \boldsymbol{\omega}_0 \\ \varphi_{\mathbf{g}_0}(\mathbf{x}_t) &= ((\mathbf{q} * \mathbf{q}_0)^T (\mathbf{q}_0^{-1} * \boldsymbol{\omega}_b * \mathbf{q}_0 + \boldsymbol{\omega}_0)^T \ a_s \cdot a_0 \ b_s \cdot b_0)^T \\ \rho_{\mathbf{g}_0}(\mathbf{y}_t) &= ((a_0 \cdot \mathbf{q}_0^{-1} * \mathbf{y}_A * \mathbf{q}_0)^T (b_0 \cdot \mathbf{q}_0^{-1} * \mathbf{y}_B * \mathbf{q}_0)^T)^T \end{cases} \quad (23.14)$$

From Eq. (23.14), one can deduce easily that the composite transformation  $\phi_{\mathbf{g}} = (\psi_{\mathbf{g}}, \varphi_{\mathbf{g}}, \rho_{\mathbf{g}})$  is equivalent to time-constant rotations and translations in both Earth- and body-fixed frames. By posing  $\mathbf{Q} = \mathbf{q} * \mathbf{q}_0$ ,  $\boldsymbol{\Omega}_b = \mathbf{q}_0^{-1} * \boldsymbol{\omega}_b * \mathbf{q}_0 + \boldsymbol{\omega}_0$  and  $\boldsymbol{\Omega}_m = \mathbf{q}_0^{-1} * \boldsymbol{\omega}_m * \mathbf{q}_0 + \boldsymbol{\omega}_0$ , it can be demonstrated that, for instance, the 1<sup>st</sup> equation of  $\dot{\mathbf{x}}_t = f(\mathbf{x}_t, \mathbf{u}_t)$  is indeed  $G$ -invariant.

$$\begin{aligned} 2\dot{\mathbf{Q}} &= 2 \overbrace{(\mathbf{q} * \mathbf{q}_0)}^{\cdot} = \mathbf{q} * (\boldsymbol{\omega}_m - \boldsymbol{\omega}_b) * \mathbf{q}_0 \\ &= \mathbf{q} * (\mathbf{q}_0 * \mathbf{q}_0^{-1} * \boldsymbol{\omega}_m - \mathbf{q}_0 * \mathbf{q}_0^{-1} * \boldsymbol{\omega}_b) * \mathbf{q}_0 \\ &= (\mathbf{q} * \mathbf{q}_0) * [(\mathbf{q}_0^{-1} * \boldsymbol{\omega}_m * \mathbf{q}_0 + \boldsymbol{\omega}_0) - (\mathbf{q}_0^{-1} * \boldsymbol{\omega}_b * \mathbf{q}_0 + \boldsymbol{\omega}_0)] \\ &= \mathbf{Q} * (\boldsymbol{\Omega}_m - \boldsymbol{\Omega}_b) \end{aligned}$$

Followingly, the neutral element  $\mathbf{e}$  of  $G$  associated with  $\varphi_{\mathbf{g}_0}$  is given by  $(\mathbf{1}^T \ \mathbf{0}^T \ 1 \ 1)^T$  (where  $\mathbf{1} = (1 \ 0 \ 0 \ 0)^T$  and  $\mathbf{0} = (0 \ 0 \ 0)^T$ ). Therefore, the moving frame  $\gamma(\mathbf{x}_t)$  which conveys any state vector to  $\mathbf{e}$  is given by

$\mathbf{x}_t^{-1} = (\mathbf{q}^{-T} (-\mathbf{q} * \boldsymbol{\omega}_b * \mathbf{q}^{-1})^T 1/a_s 1/b_s)^T$ . Consequently, the analytical expression of the invariant output error  $\mathbf{E}$  reads in this applicative case:

$$\mathbf{E}(\hat{\mathbf{x}}_t, \mathbf{l}_{\mathbf{u}_t}^{\hat{\mathbf{x}}_t}, \mathbf{z}_t) = h(\mathbf{e}, \mathbf{l}_{\mathbf{u}_t}^{\hat{\mathbf{x}}_t}) - \rho_{\hat{\mathbf{x}}_t^{-1}}(\mathbf{z}_t) = \begin{pmatrix} \mathbf{E}_A = \mathbf{A} - \hat{a}_s^{-1} \cdot \hat{\mathbf{q}} * \mathbf{a}_m * \hat{\mathbf{q}}^{-1} \\ \mathbf{E}_B = \mathbf{B} - \hat{b}_s^{-1} \cdot \hat{\mathbf{q}} * \mathbf{b}_m * \hat{\mathbf{q}}^{-1} \end{pmatrix} \quad (23.15)$$

In Eq. (23.15),  $\mathbf{b}_m$  is the magnetic field measurement. Besides, the invariant basis vectors can be also clarified. By posing  $\mathbf{W}(\hat{\mathbf{x}}_t) = \{(\mathbf{w}_i^{\hat{\mathbf{q}}})_{i \in \llbracket 1; 3 \rrbracket} (\mathbf{w}_i^{\hat{\boldsymbol{\omega}}_b})_{i \in \llbracket 1; 3 \rrbracket} \mathbf{w}^{\hat{a}_s} \mathbf{w}^{\hat{b}_s}\}$  the invariant vectors basis and considering  $\mathcal{B} = (\mathbf{v}_i)_{i \in \llbracket 1; 3 \rrbracket}$  the canonical basis of  $\mathbb{R}^3$ , we have:

$$\mathbf{W}(\hat{\mathbf{x}}_t) = \left\{ \begin{pmatrix} \mathbf{v}_i * \hat{\mathbf{q}} \\ \mathbf{0} \\ 0 \\ 0 \end{pmatrix}_{i \in \llbracket 1; 3 \rrbracket} \begin{pmatrix} \mathbf{0} \\ \hat{\mathbf{q}}^{-1} * \mathbf{v}_i * \hat{\mathbf{q}} \\ 0 \\ 0 \end{pmatrix}_{i \in \llbracket 1; 3 \rrbracket} \begin{pmatrix} \mathbf{0} \\ \mathbf{0} \\ a_s \\ 0 \end{pmatrix} \begin{pmatrix} \mathbf{0} \\ \mathbf{0} \\ 0 \\ b_s \end{pmatrix} \right\}$$

Mixing all these results allows to derive the equations of a continuous-time **IUKF** estimator s.t.:

$$\begin{cases} \dot{\hat{\mathbf{q}}} = \frac{1}{2} \hat{\mathbf{q}} * (\boldsymbol{\omega}_m - \hat{\boldsymbol{\omega}}_b) + \sum_{i=1}^3 (\bar{\mathbf{K}}_i^{1:3}[\mathbf{E}] \cdot \mathbf{E}_A + \bar{\mathbf{K}}_i^{4:6}[\mathbf{E}] \cdot \mathbf{E}_B) \mathbf{v}_i * \hat{\mathbf{q}} + \mathbf{C}_{\hat{\mathbf{q}}} \\ \dot{\hat{\boldsymbol{\omega}}_b} = \hat{\mathbf{q}}^{-1} * \left( \sum_{i=4}^6 (\bar{\mathbf{K}}_i^{1:3}[\mathbf{E}] \cdot \mathbf{E}_A + \bar{\mathbf{K}}_i^{4:6}[\mathbf{E}] \cdot \mathbf{E}_B) \right) * \hat{\mathbf{q}} \\ \dot{\hat{a}}_s = \hat{a}_s \cdot (\bar{\mathbf{K}}_7^{1:3}[\mathbf{E}] \cdot \mathbf{E}_A + \bar{\mathbf{K}}_7^{4:6}[\mathbf{E}] \cdot \mathbf{E}_B) \\ \dot{\hat{b}}_s = \hat{b}_s \cdot (\bar{\mathbf{K}}_8^{1:3}[\mathbf{E}] \cdot \mathbf{E}_A + \bar{\mathbf{K}}_8^{4:6}[\mathbf{E}] \cdot \mathbf{E}_B) \end{cases} \quad (23.16)$$

In the previous equation, the notation  $\bar{\mathbf{K}}_i^{j:k}[\mathbf{E}]$  (with  $i \in \llbracket 1; n \rrbracket$  and  $(j, k) \in (\mathbb{N}^*)^2$ ) designates the gain submatrix obtained by concatenating the columns of  $\bar{\mathbf{K}}_i[\mathbf{E}]$  between the  $j^{\text{th}}$  and the  $k^{\text{th}}$  positions. The gain computation follows the steps presented in §23.3.2. The additive (and invariant) vector  $\mathbf{C}_{\hat{\mathbf{q}}}$ , which reads  $(1 - \|\hat{\mathbf{q}}\|^2)\hat{\mathbf{q}}$ , permits to keep  $\|\hat{\mathbf{q}}\| = 1$  through time along the estimation process. In the **AHRS** case, it is noteworthy that the estimator equations in discrete time can be expressed as a global weighted sum of individual predictions and correction terms (see [20] for more details) thanks to both: - the form of the observation equations (cf. Eq. (23.13)) which are linear w.r.t. to  $\mathbf{A}$  and  $\mathbf{B}$ ; - and the resort to an unscented-based (*i.e.*, sampling) technique for gains computation. Followingly, by denoting  $\boldsymbol{\eta}(\mathbf{x}_t, \hat{\mathbf{x}}_t) = (\boldsymbol{\alpha} \boldsymbol{\beta} \boldsymbol{\mu} \boldsymbol{\nu})^T = ((\hat{\mathbf{q}} * \mathbf{q} - \mathbf{1})^T (\hat{\mathbf{q}} * (\hat{\boldsymbol{\omega}}_b - \boldsymbol{\omega}_b) * \hat{\mathbf{q}}^{-1})^T a_s / \hat{a}_s b_s / \hat{b}_s)^T$ , the invariant state estimation error dynamics is given by:

$$\begin{cases} \dot{\boldsymbol{\alpha}} = -\frac{1}{2} \boldsymbol{\alpha} * \boldsymbol{\beta} + \left( \sum_{i=1}^3 \bar{\mathbf{K}}_i^{1:3}[\mathbf{E}] \cdot \mathbf{E}_A + \bar{\mathbf{K}}_i^{4:6}[\mathbf{E}] \cdot \mathbf{E}_B \right) * \boldsymbol{\alpha} \\ \dot{\boldsymbol{\beta}} = (\boldsymbol{\alpha}^{-1} * \mathbf{l}_{\mathbf{u}_t}^{\hat{\mathbf{x}}_t} * \boldsymbol{\alpha}) \times \boldsymbol{\beta} + \boldsymbol{\alpha}^{-1} * \left( \sum_{i=4}^6 (\bar{\mathbf{K}}_i^{1:3}[\mathbf{E}] \cdot \mathbf{E}_A + \bar{\mathbf{K}}_i^{4:6}[\mathbf{E}] \cdot \mathbf{E}_B) \right) * \boldsymbol{\alpha} \\ \dot{\boldsymbol{\alpha}} = -\boldsymbol{\alpha} \cdot (\bar{\mathbf{K}}_7^{1:3}[\mathbf{E}] \cdot \mathbf{E}_A + \bar{\mathbf{K}}_7^{4:6}[\mathbf{E}] \cdot \mathbf{E}_B) \\ \dot{\boldsymbol{\gamma}} = -\boldsymbol{\gamma} \cdot (\bar{\mathbf{K}}_8^{1:3}[\mathbf{E}] \cdot \mathbf{E}_A + \bar{\mathbf{K}}_8^{4:6}[\mathbf{E}] \cdot \mathbf{E}_B) \end{cases}$$

As it was beforementioned, the reader can notice that the invariant state estimation error dynamics depends on system's trajectory  $t \mapsto (\mathbf{x}_t, \mathbf{u}_t)$  through the invariant quantity  $\mathbf{I}_{\mathbf{u}_t}^{\mathbf{x}_t}$  which is a major difference with most of nonlinear estimators. Unlike the Invariant Extended Kalman Filter (**IEKF** - see references [18,19]), the proposed **IUKF** does not require a linearization of  $\dot{\boldsymbol{\eta}}(\mathbf{x}_t, \dot{\mathbf{x}}_t)$  w.r.t.  $\boldsymbol{\eta}$  for its gain matrix computation step. This linearization can appear as a difficult operation in itself and especially for any practical implementation.

### 23.4.3 Results

The **IUKF** performances have been widely evaluated. A concise comparison of them with the ones provided by a standard **UKF** approach is presented in this section. The reference input/output data used in this paragraph have been obtained from the simulation of an automated free falling parafoil modeling. Standard additive pseudo-Gaussian noises have been added to the simulated measurements. The continuous-time **IUKF**-based estimator of Eq. (23.16) has been implemented numerically using a 4<sup>th</sup>-order Runge-Kutta integration technique, sampled at 50Hz. The time horizon length is approximately equal to 100 seconds. During this simulation, system's dynamics is characterized by strong variations of some state variables, for instance the parafoil attitude angles and its free falling speed. This can be observed in particular until  $t = 40$  seconds. Obviously, processing such data will impact and test the whole estimation process since this latter relies on the assumption that  $\dot{\mathbf{V}} = \mathbf{0}$ . At the top of Fig. (23.5), the estimations of the 3<sup>rd</sup> component of the state sub-vector  $\mathbf{q} = (q_1 \ q_2 \ q_3 \ q_4)^T$  restored by the 2 methods are displayed through time. It shows that both algorithms are very close to the true  $q_3$  value. Besides, the initial state error, introduced on purpose, appears quickly corrected ( $< 1$  second). However, at the bottom of Fig. (23.5), the analysis of the state estimation errors magnitude on the parafoil attitude angles reveals that the **IUKF** method is more accurate and converges faster than the **UKF**. Another noticeable difference can be observed on the theoretical standard deviation computed by both algorithms. Due to its invariance properties, the **IUKF** produces more reliable estimates w.r.t. to the standard **UKF** algorithm. This invariant behaviour can also be assessed on Fig. (23.6) which provides, among other things, the time variations of the correction gains calculated by the standard estimation technique and the **IUKF**. Indeed, it is noteworthy that, by exploiting the invariances of system dynamics within the nonlinear state estimation approach (*i.e.*, the **IUKF**), the correction gains (associated here with  $\hat{q}_3$ ) appear constants along the followed trajectory, whereas they vary in a chaotic way for the **UKF**. The bottom of Fig. (23.6) illustrates for its part the good convergence property of the developed **IUKF**. Indeed, the subplots show the evolution (over the 20 first seconds) of the norm of both linear (**UKF** case) and invariant (**IUKF** case) estimation error vectors, associated with the  $\boldsymbol{\omega}_b$  state, for 3 different initial conditions. Different trajectories are followed

by the standard **UKF** whereas an unique path characterized the convergence of the **IUKF**.

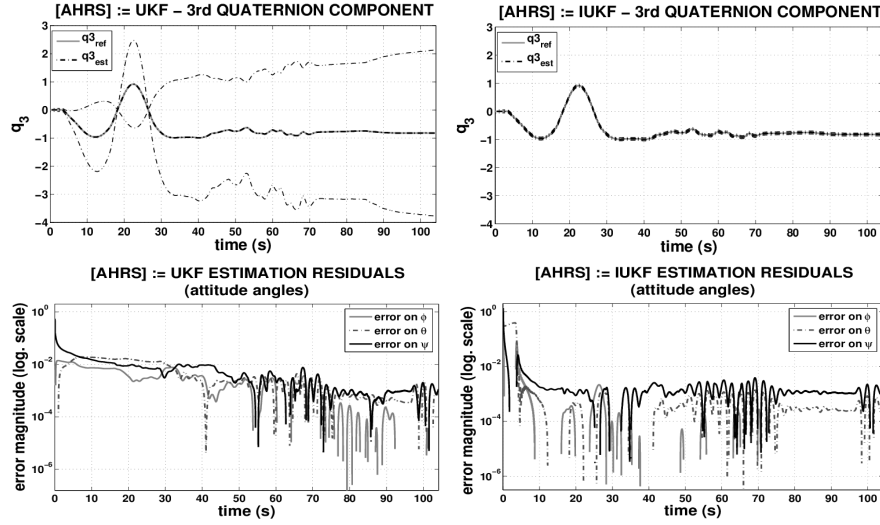

**FIGURE 23.5** Resulting  $q_3$  estimates (dash-dot lines := estimated standard deviation) and errors magnitude on parafoil attitude angles [**UKF** (left) - **IUKF** (right)].

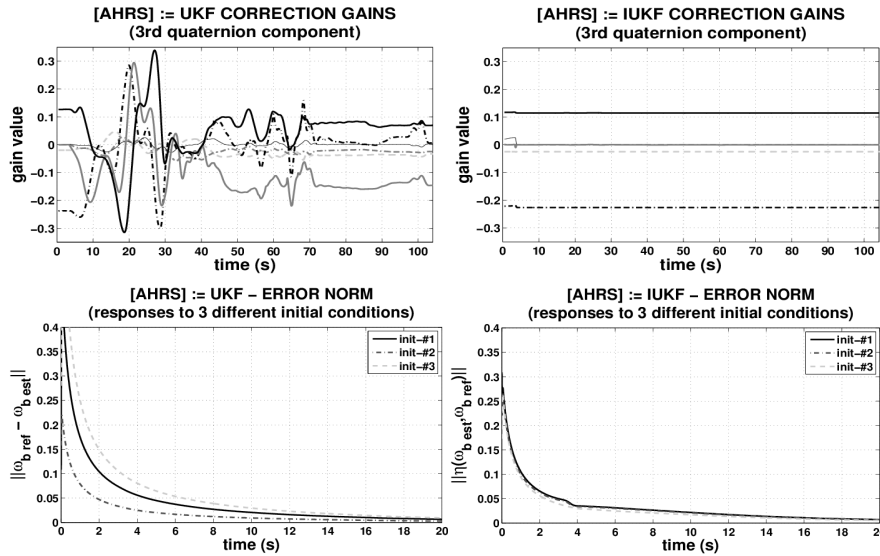

**FIGURE 23.6** Correction gains time variations and estimation error norm convergence [**UKF** (left) - **IUKF** (right)].

---

## Bibliography

- [1] S. C. Patwardhan *et al.*, “Nonlinear Bayesian state estimation: A review of recent developments,” *Control Engineering Practice*, 20, pp. 933-953, 2012.
- [2] J. L. Crassidis, F. L. Markley and Y. Cheng, “Survey of Nonlinear Attitude Estimation Methods,” *Journal of Guidance, Control and Dynamics*, 30(1), pp. 12-28, Jan-Feb 2007.
- [3] J. L. Crassidis and J. L. Junkins, *Optimal Estimation of Dynamic Systems*, Chapman & Hall/CRC Press LLC, 2004.
- [4] N. Aghannan and P. Rouchon, “On invariant asymptotic observers,” *IEEE Conf. on Decision and Control*, pp. 1479-1484, Dec 2002.
- [5] P. Martin and E. Salaun, “Invariant observers for attitude and heading estimation from low-cost inertial and magnetic sensors,” *IEEE Conf. on Decision and Control*, pp. 1039-1045, Dec 2007.
- [6] P. Martin and E. Salaun, “An invariant observer for earth-velocity-aided attitude heading reference systems,” *IFAC World Congress*, Jul 2008.
- [7] S. Bonnabel, “Left-invariant Extended Kalman Filter and attitude estimation,” *IEEE Conf. on Decision and Control*, pp. 1027-1032, Dec 2007.
- [8] S. Bonnabel, P. Martin and P. Rouchon, “Symmetry-preserving observers,” *IEEE Tans. on Automatic Control*, 53(11), pp. 2514-2526, 2008.
- [9] S. Bonnabel, P. Martin and P. Rouchon, “Non-linear Symmetry-preserving Observers on Lie groups,” *IEEE Tans. on Automatic Control*, 54(7), pp. 1709-1713, 2009.
- [10] S. Bonnabel, P. Martin and E. Salaun, “Invariant Extended Kalman Filter: Theory and Application to a Velocity-Aided Attitude Estimation Problem,” *IEEE Conf. on Decision and Control*, pp. 1297-1304, Dec 2009.
- [11] M. Barczyk and A. F. Lynch, “Invariant Observer Design for Helicopter UAV Aided Inertial Navigation System,” *IEEE Trans. on Control Sys. Technology*, 21(3), pp. 791-806, 2013.
- [12] J-P. Condomines, C. Seren and G. Hattenberger, “Nonlinear state estimation using an invariant unscented Kalman filter,” *AIAA GNC Conf.*, 2013.



- [13] J-P. Condomines, C. Seren and G. Hattenberger, "Pi-Invariant Unscented Kalman Filter for Sensor Fusion," *IEEE Conf. on Decision and Control*, pp. 1035-1040, Dec 2014.
- [14] A. Barrau and S. Bonnabel, "Invariant Particle Filtering with application to localization," *IEEE Conf. on Decision and Control*, pp. 5599-5605, Dec 2014.
- [15] A. Barrau and S. Bonnabel, "Intrinsic filtering on Lie groups with applications to attitude estimation," *IEEE Tans. on Automatic Control*, 60(2), pp. 436-449, 2015.
- [16] A. Khosravian *et al.*, "Observers for invariant systems on Lie groups with biased input measurements and homogeneous outputs," *Automatica*, 55, pp. 19-26, 2015.
- [17] N. Aghannan, "Contrle de Racteurs de Polymrisation, observateur et invariance," *PhD thesis*, Mines ParisTech, Nov 2003.
- [18] S. Bonnabel, "Invariant asymptotic observers: theory and examples," *PhD thesis*, Mines ParisTech, Sep 2007.
- [19] E. Salaun, "Filtering algorithms and avionics systems for unmanned aerial vehicles," *PhD thesis*, Mines ParisTech, Jan 2009.
- [20] J-P. Condomines, "Nonlinear state estimation for guidance and navigation of unmanned aerial vehicles flying in a complex environment," *PhD thesis*, University of Toulouse, ISAE, Feb 2015.
- [21] J. J. LaViola Jr, "A comparison of unscented and extended Kalman filtering for estimating quaternion motion," *American Control Conf.*, pp. 2190-2195, Jul 2004.
- [22] S. Sarkka, "On unscented kalman filtering for state estimation of continuous-time nonlinear systems," *IEEE Trans. on Automatic Control*, 52(9), pp. 1631-1641, Sep 2007.
- [23] S. J. Julier and J. K. Uhlmann, "Unscented filtering and nonlinear estimation," *Proc. of the IEEE*, 92(3), pp. 401-422, Mar 2004.
- [24] S. J. Julier, "The scaled unscented transformation," *American Control Conf.*, pp. 4555-4559, May 2002.
- [25] R. van der Merwe and E. A. Wan, "The square-root unscented Kalman filter for state and parameter estimation," *IEEE Int'l Conf. on Acoustics, Speech and Signal Processing*, pp. 3461-3464, May 2001.
- [26] H. Ghanbarpour Asl and S. H. Pourtakdoust, "UD covariance factorization for unscented Kalman filter using sequential measurements update," *Int'l Journal of Mechanical, Aerospace, Industrial, Mechatronic and Manufacturing Eng.*, 1(10), 2007.

- [27] D. Li *et al.*, “Invariant Observer-Based State Estimation for Micro-Aerial Vehicles in GPS-Denied Indoor Environments Using an RGB-D Camera and MEMS Inertial Sensors,” *Micromachines*, 6, pp. 487-522, 2015.
- [28] M. Barczyk, S. Bonnabel and J-E. Deschaud, “Invariant EKF Design for Scan Matching-Aided Localization,” *IEEE Tans. on Control Sys. Technology*, 23(6), pp. 2440-2448, Nov 2015.
- [29] S. Diemer and S. Bonnabel, “An Invariant Linear Quadratic Gaussian controller for a simplified car,” *IEEE Conf. on Robotics and Automation*, pp. 448-453, May 2015.
- [30] G. Rudolph and M. Schmidt, *Differential Geometry and Mathematical Physics - Part I: Manifolds, Lie Groups and Hamiltonian Systems*, Springer, 2012.
- [31] M. Fecko, *Differential Geometry and Lie Groups for Physicists*, Cambridge Univ. Press, Mar 2011.
- [32] P. J. Olver, *Classical Invariant Theory*, Cambridge Univ. Press, 1999.