



HAL
open science

Using ANN and UAV for Terrain Surveillance: A Case Study for Urban Areas Observation

Luiz F. Felizardo, Rodrigo L. Mota, Elcio H. Shiguemori, Marcos T. Neves, Alexandre Carlos Brandao-Ramos, Felix Mora-Camino

► To cite this version:

Luiz F. Felizardo, Rodrigo L. Mota, Elcio H. Shiguemori, Marcos T. Neves, Alexandre Carlos Brandao-Ramos, et al.. Using ANN and UAV for Terrain Surveillance: A Case Study for Urban Areas Observation. HIS 2013, 13th International Conference on Hybrid Intelligent Systems, Dec 2013, Gammarth, Tunisia. 10.1109/HIS.2013.6920414 . hal-01078501

HAL Id: hal-01078501

<https://enac.hal.science/hal-01078501>

Submitted on 29 Oct 2014

HAL is a multi-disciplinary open access archive for the deposit and dissemination of scientific research documents, whether they are published or not. The documents may come from teaching and research institutions in France or abroad, or from public or private research centers.

L'archive ouverte pluridisciplinaire **HAL**, est destinée au dépôt et à la diffusion de documents scientifiques de niveau recherche, publiés ou non, émanant des établissements d'enseignement et de recherche français ou étrangers, des laboratoires publics ou privés.

Using ANN and UAV for Terrain Surveillance

A Case Study for Urban Areas Observation

Luiz F. Felizardo^{#1}, Rodrigo L. Mota^{#2}, Elcio H. Shiguemori^{*3}, Marcos T. Neves^{#4},

Alexandre B. Ramos^{#5} and Felix Mora-Camino⁺⁶

*#Institute of Mathematics and Computing, Federal University of Itajubá
BPS Av., 1303, Pinheirinho – Itajubá, MG – Brazil*

**Institute of Advanced Studies, Department of Aerospace Science and Technology
Tamoios Highway, 1, Putim – São José dos Campos, SP – Brazil*

+Ecole Nationale de l'Aviation Civile

7 Av. Edouard-Belin, CS 54005, Toulouse Cedex 4 – France

1 - lfvarinha@unifei.edu.br 2 - rodrigolmmota@gmail.com

3 - elcio@ieav.cta.br 4 - marcostheiss@gmail.com

5 - ramos@unifei.edu.br 6 - felix.mora@enac.fr

Abstract— Autonomous Unmanned Aerial Vehicles (UAVs) provide an effective alternative for surveillance in urban areas due to their cost and safety when compared to other traditional methods. The objective of this study is to report the development of a system capable of analyzing digital images of the terrain and identifying potential invasion, unauthorized changes in land and deforestation in some special urban areas. Images are captured by a camera attached to an autonomous helicopter, flying it around the area. For processing the images, an Artificial Neural Network (ANN) technique called Self Organizing Map (SOM) is used.

Keywords – Pattern recognition, surveillance, UAV, autonomous helicopter, Kohonen SOM

INTRODUCTION

The development of the technology of digital image processing has enabled the interest in detecting changes in multiple images of the same scene, due to the large number of applications, focusing primarily in the areas of security, soil analysis and medical diagnosis.

In the area of security, for example, there are studies that address the use of aerial robots in border areas for monitoring, [1], on the other hand, there are studies in the medical field for the detection and classification of breast tumors in pictures using ultrasound imaging features [2], and in the area of soil analysis, studies verify changes in the classification of urban areas using a multi-Layer Perceptron (MLP) [3]. In all these cases there is a large amount of data that must be processed so that relevant information can be extracted from the images and thus changes can be diagnosed, however, these studies utilize methods that are computationally expensive and results may take time to appear.

Also enough interest has grown in the use of Unmanned Aerial Vehicles (UAVs) to collect information, initially in the

military and more recently also in the civil sector. Due to their low cost, there has been an increase in the need to enable UAVs into missions to collect information autonomously, in other words, without human intervention.

Currently it is very common to find areas of restricted use in many countries which need to be monitored so as to ensure their integrity by avoiding invasions, deforestation, unauthorized alterations on the ground and etc. The use of UAVs for monitoring has greatly increased in recent years, especially with the combined use of sensor data like the Global Positioning System (GPS) and the Inertial Measurement Unit (IMU) to perform the registration of the location of the images [4, 5].

Given the factors described above, the use of UAV in ground inspection of forests areas and transmission lines becomes an attractive alternative. UAVs can travel considerable distances with higher security and a much lower cost than other traditional methods could provide, for example, the use crewed helicopters. With factors like fatigue and tiredness due to extensive hours of work, the human eye can often fail on the mission of detecting a change in the terrain. An autonomous helicopter is able to capture images from different angles, can be then processed by a neural network, so that the locations with the highest probability of finding invasions are spotted.

Artificial Neural Networks (ANN) are an artificial intelligence modelling technique which attempts to emulate the computational abilities of the human brain, where knowledge is maintained through the connections between neurons (synapses). The Kohonen SOM is a kind of competitive neural network with unsupervised learning [6]. For each input signal only the neuron that has the highest affinity with it will be activated. That is, if the inputs of the neural network are the pixels of an image, for each pixel only one neuron is activated by setting the group or class that this

pixel belongs. At the end of the process, there is a new output image with pixels grouped according to similar characteristics.



Figure 1 - Chosen Helicopter

The objective of this paper is to report a system that can collect and analyse aerial images of the ground under special areas, and elect (through images) most likely problematic places. The survey currently uses manned helicopters and is made by human eye analyses, which has a high cost and is likely to have significant failures. Images processed in this case are captured by autonomous helicopters, which greatly reduces the labour and process costs.

HELICOPTER PLATFORM

Aircraft

The Mini UAV shown in Figure 1 is a commercial RC helicopter chosen for its price and performance, range, reliability, etc. It has a 1.58m diameter rotor blade, which is powered by a brushless 700MX electric, and has a maximum take-off weight of 5.2kgs. The base RC platform weighs 3.2kgs with batteries, sensors and flight computers. With the basic configuration for GPS waypoint navigation, it has an endurance of 30 min. A 2.4GHz RC link is used for manual flight and a 2.4GHz wireless modem is used to transmit telemetry data to the ground station and operator commands from the ground station. This link together with the omnidirectional antennas used has a line-of-sight range of approximately 5km but if by any means the link is lost an automatic return home procedure will take command of the aircraft bringing it back to visual sight of the operator.

Autonomous Flight

All the sensors used for autonomous flight are included in a commercial integrated device, including an IMU, GPS receiver, magnetometer and barometer (see Figure 2). The device fuses the sensor data with an Extended Kalman Filter to produce a filtered state estimate of position. The onboard flight computer uses the state estimate to generate appropriate commands for autonomous flight in the form of Pulse-Width Modulation (PWM) signals which are converted to Pulse-Position Modulation (PPM) signal through a PPM encoder board. These are fed to the servos via a Lisa/M board. This board can select between pilot RC commands or flight computer commands passing through to the servos, allowing

to switch between manual, autonomous stabilization and complete autonomous flight.

The current control strategy is implemented using standard techniques. Proportional Integral Derivative (PID) loops control attitude at a high update rate, while outer loops control position and velocity at a lower rate. The PID gains have been tuned for airspeeds up to 10m/s through flight trials and system identification. This control implementation provides a reliable hover (within the error bounds of the GPS receiver), and has been used for forward flight with airspeeds of up to 18m/s. Although the controller performs well in winds with fairly constant speeds, it is not yet optimised for gusts and turbulence [7].

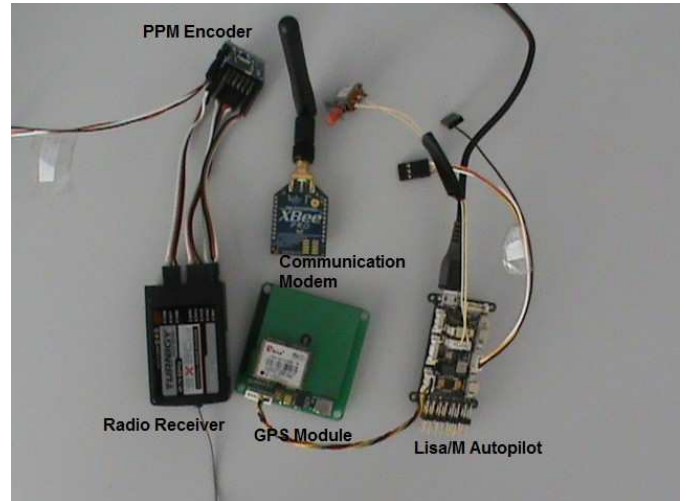

Figure 2 - Hardware Embedded in the Helicopter.

GROUND STATION

The software used in this project for aerial control is called Paparazzi [8]. It is a free and open-source hardware and software project intended to create an exceptionally powerful and versatile autopilot system for fixed-wing aircrafts as well as multi-copters by allowing and encouraging input from the community, shown in Figure 3. Many changes were made in its code for supporting our helicopter. The Paparazzi project includes not only the airborne hardware and software, from voltage regulators and GPS receivers to Kalman Filtering code, but also a powerful and ever-expanding array of ground hardware and software including modems, antennas, and a highly evolved user-friendly ground control software interface.

The versatile Paparazzi Ground Control Station is a unit ground control software for micro air vehicles. It allows the operator to visualize and control a micro air vehicle during development and operation. With a flexible software architecture, it supports multiple aircraft types/autopilot projects. The purpose of the ground control station is to have a real-time monitoring of an UAV [9].

It allows the user to change in-flight parameters such as the throttle speed, altitude among others. Not only that but it also shows flight information like the battery level, current altitude, ground speed, air speed and the top view map. With a

simple mouse click the user can change a waypoint location or switch to some other pre-defined route. Figure 3 shows a screenshot of the interface.

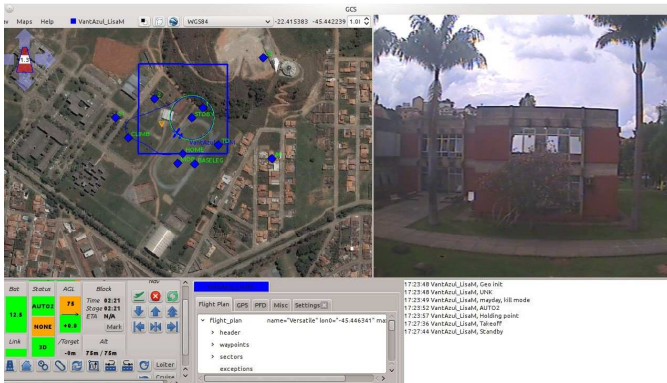

Figure 3 - Ground Control Station Interface.

IMAGE PROCESSING

A system for processing images (see Figure 4) generally has the following parts [10]:

- Image acquisition: consists of a sensor to acquire the image and a second element capable of digitizing the signal, generating a digital image.
- Pre-processing: has the function to improve the image, seeking to increase the chances of success for the following procedures. Involves techniques for contrast enhancement, noise removal and region isolation;
- Segmentation: divides an input image into parts or objects. It is one of the most difficult automatic processes in image processing. The output of this stage is usually given in the form of pixels, corresponding to the boundary of a region or its constituent points;
- Representation and description: this stage of processing the data is transformed appropriately for the computational processing that follows, stressing characteristics of interest. The process of description, also called selection of characteristics, has extracted characteristics that represent quantitative information of interest or which are fundamental in the discretion of classes and objects;
- Recognition: recognition is the process that assigns a label to an object and interpretation involves the assignment of meaning to a set of recognized objects.

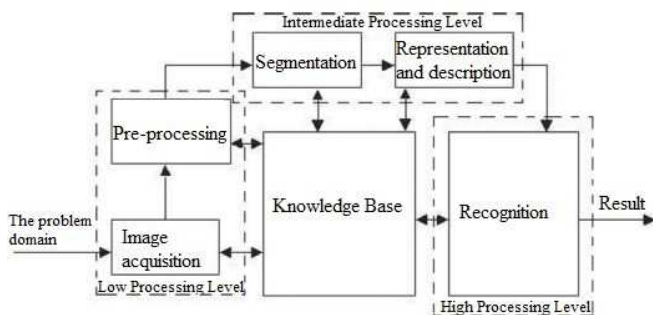

Figure 4 - Image Processing Division.

The developed system classifies digital photographed images shot from a set comprising a camera¹ coupled to a support, provided with vibration absorbers the whole in turn is mounted on an electric mini-helicopter. Images are georeferenced and the whole process of imaging is performed in a ground station that receives the photos sent by the mini-helicopter and saved in a hard disk for further processing. It allows one image to be inputted and generates a new output image where the pixels are grouped according to similar features.

KOHONEN SELF-ORGANIZING MAP

The Kohonen Self Organizing Map (SOM) is a map or matrix with non-symmetric dimension, where each element represents a neuron [11]. Neurons are interconnected and maintained relation to each other, even influencing each other. Each neuron or set of neurons represents an output and is responsible for a particular function. This feature is analogous to the brain where different information is controlled by different parts of the brain, such as speech, hearing and vision. The artificial neural network resembles other brain aspects such as: knowledge acquisition from the environment through a learning process and connection strengths between neurons - the synaptic weights - which are used to store the acquired knowledge.

The goal of SOM is the classification of the input data as the knowledge that neurons acquire. The topology between input and output is always kept, since the notions of neighborhood between neurons are not altered.

The synaptic weights are initialized randomly and during learning such weights are updated at each iteration of the algorithm. The intention of this phase is to find the neuron that has the closest characteristics of the input. Thus, after a process of iteration only one neuron is activated, however its neighbors also suffer a small influence.

SOM Kohonen Algorithm

1. Randomize the map's nodes' weight vectors;
2. Grab an input vector;
3. Traverse each node in the map:
 - 3.1 Use Euclidean distance formula to find similarity between the input vector and the map's node's weight vector.
 - 3.2 Track the node that produces the smallest distance (this node is the Best Matching Unit, BMU);
4. Update the nodes in the neighbourhood of BMU by pulling them closer to the input vector;
 - 4.1 $W_v(t + 1) = W_v(t) + \Theta(t)\alpha(t)(D(t) - W_v(t))$
5. Increase t and repeat from 2 while $t < \lambda$

Where t denotes current iteration, λ is the limit on time iteration, W_v is the current weight vector, $D(t)$ is the target input, $\alpha(t)$ is a monotonically decreasing learning coefficient and $\Theta(t)$ is restraint due to distance from BMU, usually called

¹ A Sony FCB-EX980SP camera that employs a 26x optical zoom lens combined with a digital zoom function, this camera allows to zoom up to 312x.

the neighbourhood function, and is learning restraint due to time [12].

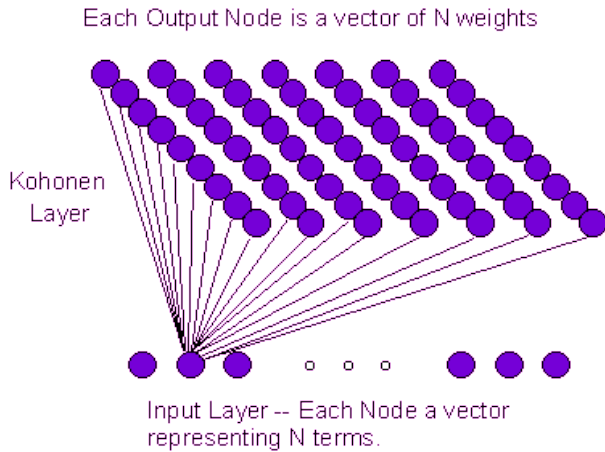

Figure 5 - Kohonen SOM Topology.

The topology of the Kohonen SOM network is shown in Figure 5. This network contains two layers of nodes - an input layer and a mapping (output) layer in the shape of a two-dimensional grid [12,13].

EXPERIMENTS AND RESULTS

A Java software program that implements the Kohonen SOM was developed. It allows one image to be input and generates a new output image where the pixels are grouped according to similar features.

For the processing some parameters must be set. These parameters are linked to which type of sensor is being used to capture images. For example, the optimal parameters for images captured by an UAV are not the same as satellite images. These parameters are:

- Number of iterations: how many times the algorithm will be repeated. Typically the higher the number of iterations the higher is the quality of the processing is. However, after a certain point the number of iterations starts to damage the quality of the output image. Thus, an intermediate number should be fit so that the quality is not compromised.

- Rate of learning: learning rate interferes with the updating of synaptic weights. A very small learning rate requires a higher number of iterations to converge to the desired result. However, a very high rate causes oscillations and also hampers convergence.

- Number of neurons: each neuron represents a class, i.e., a distinct characteristic. The number of neurons must be placed according to how the user wants to have some generalization in the grouping of neurons. The smaller the number of neurons, the more generalist grouping will be. A very high number of neurons will tend to cause the output to copy the entry, which is not desired.

To test the Kohonen SOM and better understand its operation some tests were conducted using aerial images of a

city. Table 1 below shows the parameters used in the configuration.

TABLE
KOHONEN SOM TEST

Test #	Number of Iterations	Learning Rate	Number of Neurons
Test 0	3	0.000001	2x1
Test 1	4	0.000001	2x1
Test 2	5	0.000001	2x1
Test 3	6	0.000001	2x1
Test 4	7	0.000001	2x1

The sequences of steps taken to implement the tests were:

1. The images were converted to grayscale.
2. An adjustment in brightness and color tone of the images was made.
3. The image is processed by the software that uses a Kohonen neural network.

Below we can see in the Figure 6 to Figure 9, an example of test number two.

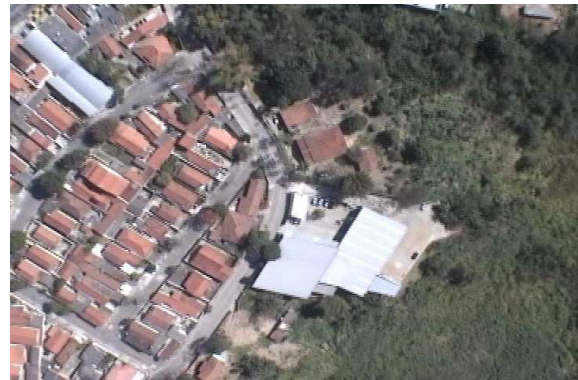

Figure 6 - Original Image Captured by the UAV.

Figure 6 was captured by the UAV over the city of São José dos Campos, Brazil.



Figure 7 - Image After the Application of Step 1.

Figure 7 is a grayscale-mode from Figure 6.



Figure 8 - Image After Brightness Change From Step 2.

Figure 8 suffered adjustments in brightness and color tone on Figure 7.

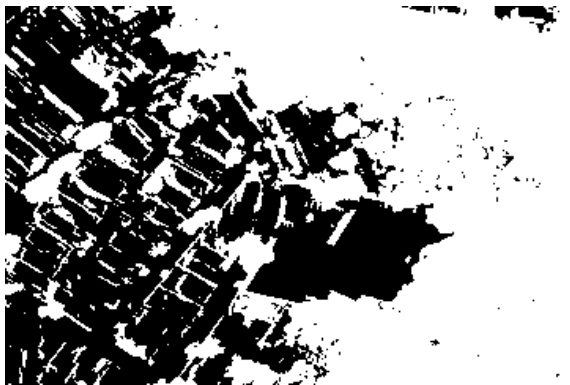

Figure 9 - Image After All 3 Steps.

Finally, Figure 9 was obtained by the processing of Figure 8 using Kohonen neural network.

The tests were made using only two neurons, one representing the color white and the other representing the color black. Steps one and two correspond to a pre-processing, which assist the image processing done by Kohonen SOM in step 3. The pre-processing makes it easier for the final process to recognize which color is closer to white (in the event trees) and witch closer to the black (the strets and the roofs of houses).

CONCLUSIONS AND FUTURE WORK

Kohonen SOM allows grouping the pixels of an image with similar characteristics. In the case of this work, the pixels become widespread in two classes - white and black. After processing, there is a new output image with the colors rearranged. The processing result is an image capable of being quickly compared with other prior images stored in the ground station. The same process can be used to detect improper construction of houses in forests areas or transmission lines areas.

UAVs are already being used in many fields today and will certainly be largely used for transmission line inspection, future works include but are not limited to improvements in the autopilot system for a better stability in gusty conditions

and the suitability of an airplane instead of a helicopter for other uses that require longer and faster distances for travelling.

ACKNOWLEDGMENT

This research has been partially supported by the Brazilian National Council for Scientific and Technological Development - CNPq Grant 238348/2012-1, 310031/2012-5 and 470186/2012-7.

REFERENCES

- [1] Gromek, A., Jenerowicz, M. Sar Imagery Change Detection Method For Land Border Monitoring, Institute of Electronic Systems , Warsaw University of Technology Space Research Centre , Polish Academy of Sciences, MultiTemp, 2011 213–216.
- [2] Su, Y., Wang, Y., Jiao, J., Guo, Y., Automatic detection and classification of breast tumors in ultrasonic images using texture and morphological features., The open medical informatics journal, vol. 5, no. Suppl 1, pp. 26–37, Jan. 2011.
- [3] Del Frate, F., Schiavon, G., Solimini, C., Dept. Informatica, P. Disp. U. T. Vergata, and I.- Roma, “Application of neural networks algorithms to QuickBird imagery for classification and change detection of urban areas,” vol. 00, no. C, pp. 1091–1094, 2004.
- [4] Y. Wang, R. R. Schultz and R. A. Fevig. Sensor fusion method using. GPS/IMU data for fast UAV surveillance video frame registration. IEEE International Conference on Acoustics, speech and signal processing – ICASSP 2009. pp 985-988.
- [5] E. Semsch, M. Jakob, D.Pavliček and M. Pěchouček. Autonomous UAV surveillance in complex urban environments. International Conference on Web Intelligent Agent Technology Workshos 2009 IEEE/WIC/ACM.pp 82-85.
- [6] S. Hrabar, T. Merz, and D. Frousheger. Development of an autonomous helicopter for aerial powerline inspections, 2010 1st International Conference on Applied Robotics for the Power Industry (CARPI 2010), pp. 1–6, Oct. 2010.
- [7] S. Haykin. Self-organizing maps. Neural networks - A comprehensive foundation, 2nd edition. Prentice-Hall, 1999.
- [8] Paparazzi Project Webpage, 2012. [Online]. Available: http://paparazzi.enac.fr/wiki/Main_Page. [Accessed: 15-Jun-2013].
- [9] Paparazzi Project Webpage, Ground Control Station, 2013. [Online]. Available: <http://paparazzi.enac.fr/wiki/GCS>. [Accessed: 12-May-2013].
- [10] R. C. Gonzales and E. R. Woods, Digital Image Processing, 3rd edition. Prentice-Hall, 2007.
- [11] A. Machado, Neuroanatomia Funcional. Livraria Atheneu, 1980.
- [12] M. Caudill, A little knowledge is a dangerous thing. AI Expert. pp. 8(6):16–22.
- [13] A. Hiotis, Inside a self-organizing map. AI Expert. pp. 8(4):38–43.