



**HAL**  
open science

## The digital TV case - Positioning using signals-of-opportunity based on OFDM modulation

Damien Serant, Olivier Julien, Lionel Ries, Paul Thevenon, Mathieu Dervin,  
Günter Hein

► **To cite this version:**

Damien Serant, Olivier Julien, Lionel Ries, Paul Thevenon, Mathieu Dervin, et al.. The digital TV case - Positioning using signals-of-opportunity based on OFDM modulation. Inside GNSS, 2011, 6 (6), pp 54-62. hal-01021629

**HAL Id: hal-01021629**

**<https://enac.hal.science/hal-01021629>**

Submitted on 5 Dec 2014

**HAL** is a multi-disciplinary open access archive for the deposit and dissemination of scientific research documents, whether they are published or not. The documents may come from teaching and research institutions in France or abroad, or from public or private research centers.

L'archive ouverte pluridisciplinaire **HAL**, est destinée au dépôt et à la diffusion de documents scientifiques de niveau recherche, publiés ou non, émanant des établissements d'enseignement et de recherche français ou étrangers, des laboratoires publics ou privés.

# The Digital TV Case

## Positioning Using Signals-of-Opportunity Based on OFDM Modulation

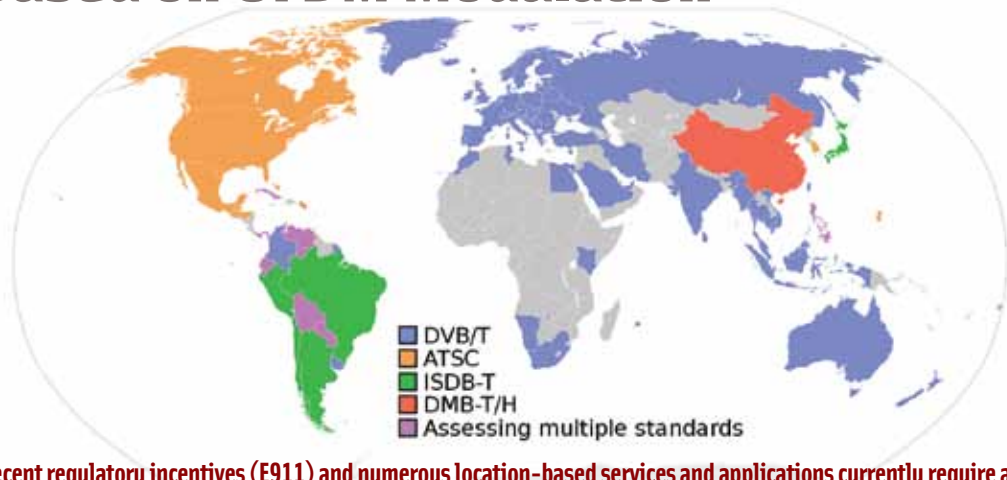

wikimedia commons

Recent regulatory incentives (E911) and numerous location-based services and applications currently require accurate urban and indoor positioning – challenging environments for GNSSes. This article investigates a means for enhancing positioning through the use of signals-of-opportunity based on the orthogonal frequency division multiplexing modulation. The authors describe the use of digital video broadcast-terrestrial signals to develop and test a pseudorange estimation method employing real signals and presents testing results that confirm previously identified theoretical results.

**DAMIEN SERANT, OLIVIER JULIEN**  
ECOLE NATIONALE DE L'AVIATION CIVILE

**LIONEL RIES, PAUL THEVENON**  
CENTRE NATIONALE D'ETUDES SPATIALES

**MATHIEU DERVIN**  
THALES ALENIA SPACE

**B**ecause of recent regulatory incentives (E911) and development of numerous location-based services (LBS) and applications, urban and indoor positioning currently represents a significant market. However, these environments are well-known for the challenges they pose for GNSS systems because of signal blockage, multipath, interference, and other factors. Even if specific GNSS developments are designed to address these issues (e.g., high-sensitivity receivers, assisted-GNSS techniques, system upgrades), they only provide limited position availability, accuracy, and continuity indoors and in urban settings.

Some alternatives exist to complement GNSS in such environments.

These include other navigation sensors (for example, inertial sensors, magnetometers, odometers, lasers, and video), dedicated radio-location systems (pseudolites, RFID, UWB) or signals-of-opportunity (SoOs).

SoOs are communication signals such as those broadcast by mobile telephony, TV, radio, or Wi-Fi operations that can also be exploited for positioning. Even if they are not meant for positioning, they have the advantage of availability and diversity in urban and indoor environments and permit, by definition, good integration of the communication and positioning services.

Among the various communication signals that could be used as SoOs, this article focuses on signals based on the orthogonal frequency division multiplexing (OFDM) modulation. OFDM appears to be a good candidate to provide a positioning service in light of increasing interest in this modulation for communication and broadcasting of actual and future signals.

From the array of OFDM-based

standards, we chose the European standard for digital television, the digital video broadcasting – terrestrial (DVB-T) standard as a candidate SoO to develop a pseudorange (PR) estimation method and perform tests on real signals. This article reports on “live” signal tests based on ranging methods previously developed by the authors that confirm the promising theoretical results seen in earlier research. Although the ranging method presented in this article is developed for DVB-T, it could be applied to other OFDM-based signals.

### OFDM Modulation

This section offers only a very brief introduction to OFDM. More detailed information on OFDM can be found in the book by Y. Li and G. Stüber listed in the Additional Resources section at the end of this article.

The OFDM modulation allows us to deal with the frequency selectivity of multipath channels that degrades wide-band transmission performance. Instead of transmitting high-rate (i.e., wide-

band) symbols on a unique carrier, the OFDM transmits low-rate (i.e., narrow-band) symbols on numerous orthogonal sub-carriers (see **Figure 1**, left). Thus, if the selected sub-carriers are narrow enough (i.e., if the symbol duration is long enough), we can consider the channel distortion as being constant over each subcarrier frequency band (Figure 1, right) and, therefore, easily estimated and corrected.

The typical OFDM modulation and demodulation schemes efficiently use iFFT and FFT techniques (inverse fast Fourier transform and fast Fourier transform, respectively), which allow for a very efficient implementation (with preferably a number of sub-carriers that is a power of two).

To avoid inter-symbol interference (ISI), a so-called *guard interval* is inserted between consecutive OFDM symbols. For instance, in the case of the DVB-T standard, this guard interval is called *cyclic prefix* (CP) since it is filled with the end of the following OFDM symbol. An illustration is shown in **Figure 2**, where  $N_{CP}$  denotes size, in a sample of the cyclic prefix. The resulting symbol (useful signal and guard interval) will be referred to in the following as an *OFDM symbol*.

**Figure 3** represents a typical OFDM modulator and demodulator. Multiple impairments affect the received samples: multipath channel distortion, timing offset (TO) due to propagation delay, and carrier frequency and sampling clock offsets (CFO and SCO) due to the difference between the local oscillator and sampling clock of the emitter and the receiver. A synchronization and correction module thus must be present in the receiver to estimate and correct for the TO, CFO and SCO. The articles by M. Morelli et alia and S. Y. Liu and J. W. Chong, listed in Additional Resources, present examples of these techniques.

Thanks to the periodicity introduced by the cyclic prefix (see Figure 2), the timing synchronization does not have to be very precise to be able to demodulate the data. If the FFT window in the demodulator starts in the CP, it will result in a phase offset that can be easily corrected during the equalization pro-

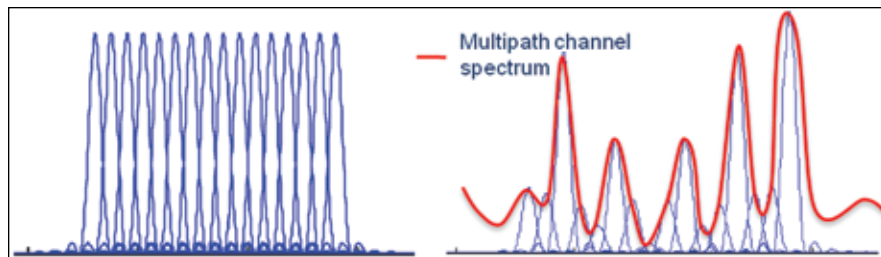

**FIGURE 1** Spectrum of OFDM orthogonal sub-carriers (left) and effect of propagation channel (right)

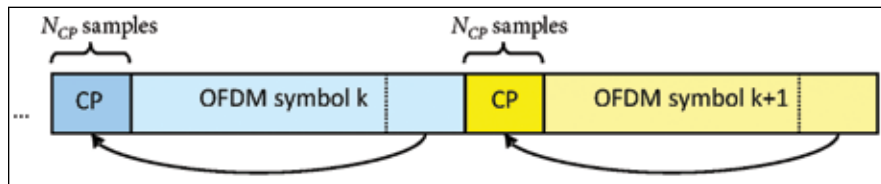

**FIGURE 2** Cyclic prefix illustration

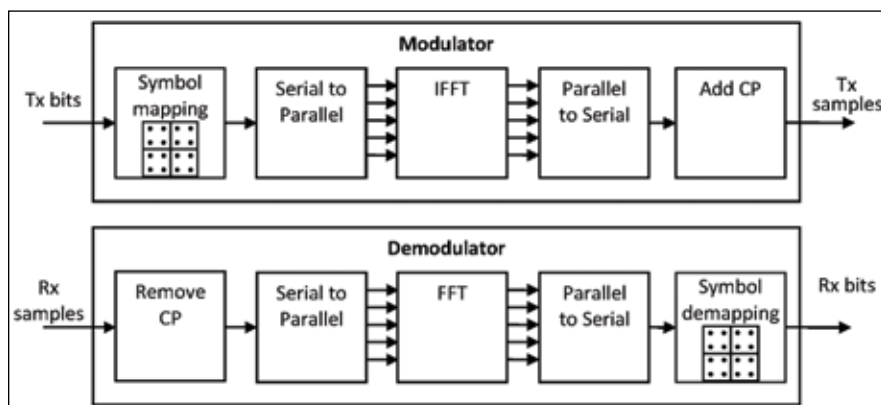

**FIGURE 3** OFDM modulator (top) and demodulator (bottom)

cess. Indeed, a subset of the sub-carriers generally includes pilot symbols, whose value and position are known by the receiver and can be used to assess the channel distortion over the frequencies.

The specific reasons to explore the OFDM modulation capability for positioning are multiple:

- OFDM modulation has been chosen for a large number of modern telecommunication and audio/video broadcast standards (known by such acronyms as Wi-Fi, WiMAX, DAB, T-DMB, DVB-T/H/SH, ISDB-T, and LTE). This preeminence of OFDM-based signals makes them obvious candidates for use as signals-of-opportunity for ranging applications, as well as good candidates for navigation/communication services.
- OFDM timing and frequency acquisition is very simple and fast thanks

to the presence of the CP.

- OFDM signals include pilot symbols that allow for computing correlations between the received signal and a receiver-generated local replica, thus laying the groundwork for precise synchronization (as in GNSS).
- The robustness of OFDM against multipath interference enables operation in single-frequency networks (SFNs). An SFN is a network in which all the emitters send the same signal at the same frequency in a synchronized way (usually based on GPS time and frequency). An SFN can be very useful for extending the coverage of an emitter into isolated/masked areas without requiring an additional frequency. From a positioning point of view, an SFN is also extremely interesting because it allows for the track-

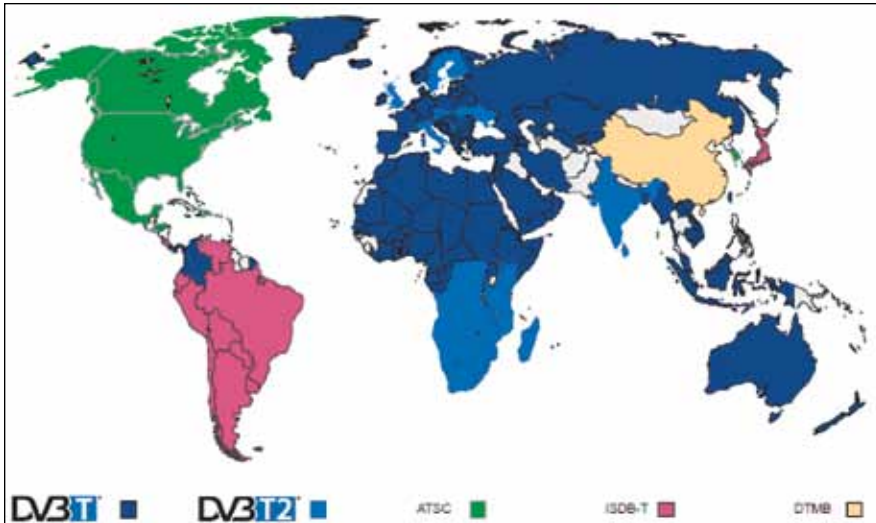

FIGURE 4 Countries that have deployed or adopted DVB-T and its evolution DVB-T2 (from DVB World-wide).

Parameters	Possible values
$N$	2048 (Mode 2K), 4096 (Mode 4K) and 8192 (Mode 8K)
$CP$	1/32, 1/16, 1/8, 1/4
$T_{smp}$	7/64 $\mu$ s (8 MHz channels), 1/8 $\mu$ s (7 MHz), 7/48 $\mu$ s (6 MHz) and 7/40 $\mu$ s (5 MHz)

TABLE 1. Possible DVB-T signal parameters

ing of multiple signals coming from several synchronized emitters on the same frequency (only one tuner required). Synchronization of the emitters means that the monitoring of the emitter clock drift might not be needed. Examples of techniques to use SFN for positioning can be found in the article by P. Thevenon et alia (2009a).

### The DVB-T Standard

DVB-T is a European standard used worldwide (see Figure 4), and based on an OFDM air-interface for digital TV broadcasting to fixed receivers in the VHF and UHF bands. This standard defines a family of OFDM signals that depends on three parameters:

- the number of subcarriers, or the FFT size ( $N$ ),
- the ratio between the cyclic prefix length and the useful OFDM symbol length ( $CP = N_{CP}/N$ ), which provides flexibility according to the expected multipath delay, and
- the sampling period ( $T_{smp}$ ), which controls the bandwidth of the DVB-T signal.

Table 1 shows various possible values defined in the DVB-T standard for each parameter. The  $N$  subcarriers of the useful OFDM symbol carry different kinds of information:

- *Null* subcarriers are located on the edges of the signal spectrum and have a zero value. They serve as guard bands to avoid out-of-band emissions of the OFDM signal.
- *Data* subcarriers are QAM-modulated (QPSK, 16-QAM and 64-QAM are possible) and have their amplitude normalized in such a way that their variance is unitary.
- *Transmission Parameter Signaling* (TPS) subcarriers are BPSK-modulated and carry information about the actual transmission parameters.
- *Pilot* subcarriers are BPSK-modulated. Their value is given by a known pseudorandom binary sequence (PRBS). Their amplitude is boosted by a factor of 4/3 compared to the data and TPS subcarriers.

The pilot subcarriers can be of two types: *continuous pilots* and *scattered pilots*. Continuous pilots are always located on the same subcarriers on every

OFDM symbol. In contrast, scattered pilots are inserted every 12 subcarriers, and the first pilot subcarrier index takes four different values (3, 6, 9, or 12) depending on the OFDM symbol number. Therefore, the scattered pilot pattern repeats every four OFDM symbols. This organization is illustrated in Figure 5 where only non-null subcarriers are represented.

### Using DVB-T to Test OFDM's Positioning Capability

As stated earlier, the investigation of ranging techniques using the DVB-T standard has its origin in the desire to assess the capability and feasibility of an OFDM-based positioning system. Even if it is not the best candidate for an operational system (particularly because of the generally low density of emitters in most areas), DVB-T can be seen as a potential complement to GNSS-based positioning (especially because DVB-T emitters are generally synchronized with GPS time). This broadcast standard is also well-suited for testing OFDM-based ranging for the following reasons:

- The signal definition is very simple (no specific pilot OFDM symbols, classic pilot grid), which makes the reuse of this work possible for other OFDM-based standards.
- DVB-T is already deployed and operational (in France and many other countries), which facilitates the testing on real signals needed to assess the performance of the ranging technique.
- Both multi-frequency networks (MFNs) and SFNs are available, thus permitting the testing of two ranging solutions.
- It is a wide-band signal (five to eight megahertz) that could offer promising synchronization capabilities.

When comparing DVB-T to GNSS, we must keep in mind that the former is a *terrestrial* communication system. In terrestrial networks, the direct signal comes from emitters that are often close to the horizon. Consequently, the direct signal (mandatory for accurate ranging based on propagation time measurements) may be blocked, and multipath

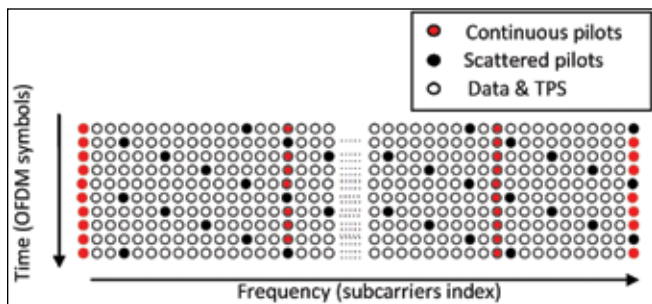

FIGURE 5 DVB-T pilot organization

signals can be both numerous and powerful, especially in urban areas. Some multipath signals are even more powerful than the direct signal.

The European Telecommunications Standards Institute (ETSI) standard for DVB-T takes this situation into account in describing the power delay profile of the propagation channel used to assess demodulation performance. Numerous multipaths are not a problem for DVB-T signal demodulation thanks to the simple and efficient OFDM channel equalization achieved with the pilot sub-carriers, as long as the maximum multipath delay remains less than the CP duration to avoid ISI. On the other hand, for positioning applications based on timing measurements these numerous multipath signals are a problem that must be specifically handled.

### Proposed DVB-T Ranging Method

Our proposed DVB-T ranging method was presented in the article by P. Thevenon *et alia* (2009b). More details on the technique can be found in the following publications listed in the Additional Resources section: D. Serant *et alia* (2010a), D. Serant *et alia* (2010b), P. Thevenon, and P. Thevenon *et alia* (2011). The method is based on the computation of a classical correlation between the received signal and a local replica, which is used during the acquisition and tracking phases.

The local replica used to compute the correlation function is composed of the pilot sub-carriers only. (The other subcarriers, unknown *a priori* by the receiver, are set to zero). The resulting correlation function can easily be shown to be a sinc function. (See its absolute

value in Figure 6.)

The width of the correlation peak is approximately 2.4 sample periods or equivalently 80 meters for eight-megahertz channels, 90 meters for seven-megahertz channels, 105 meters for six-megahertz channels, and 130 meters for five-megahertz channels.

The standard deviation of the delay tracking error using this technique was derived theoretically and validated through simulations described by Serant *et alia* (2010b) for an ideal additive white Gaussian noise (AWGN) channel. This earlier study showed that the proposed DVB-T tracking technique has a tracking threshold about 30 to 40 decibels below the DVB-T demodulation threshold, meaning that even when strong fading occurs, a good chance exists that the signal can still be used for ranging.

The study also showed that even for signal-to-noise ratio (SNR) values around -15 decibels, the ranging accuracy in AWGN is at the decimeter level, thus showing promising results. Of course, these very good results are valid for AWGN channels, which are almost never encountered in terrestrial networks. However, they give a good idea of the potential of DVB-T signals and more generally of OFDM signals to be used as SoO for positioning.

Due to the specificities of the terrestrial propagation channel already discussed, the correlation function obtained from real signals will present multiple peaks corresponding to all the replicas of the transmitted signal reaching the receiver. These peaks can evolve very fast (e.g., fading) due to the chang-

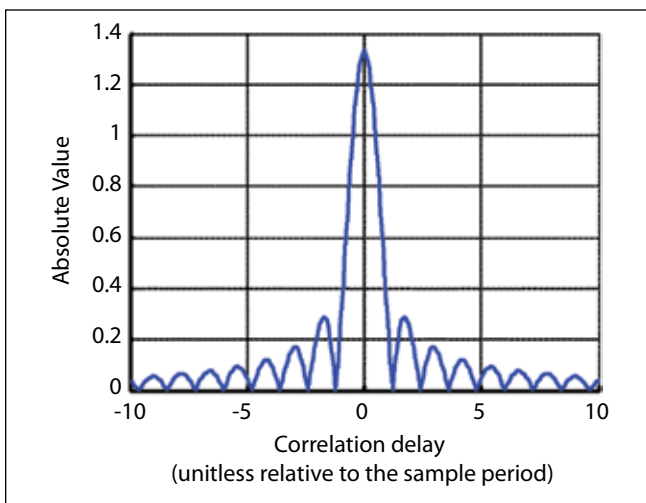

FIGURE 6 Absolute correlation function of local replica of DVB-T signal

ing environment in urban conditions. More notably, the peak corresponding to the first received signal (the one of interest for ranging) is not necessarily the most powerful and might not even be present.

In order to try to always track the shortest signal (either the direct signal or, by default, one of the shortest replicas), the proposed ranging method uses multiple delay lock loops (DLL) in order to constantly track several correlation peaks. This allows one to rely on the second tracked shortest replica if the first one disappears due to fading or signal blockage.

The following method is then used (although slight variations are required, depending on whether or not the emitters are in an SFN):

- First, an iterative algorithm, e.g., Matching Pursuit or ESPRIT (described in the cited works by, respectively, S. F. Cotter and B. D. Rao, and A. Paulraj *et alia*), is used to acquire the delays corresponding to the different peaks of the correlation function. In order to make sure that we do not miss the direct signal or the shortest detectable replica, this acquisition is run periodically.
- Second, all (or a subset of all) the acquired peaks are tracked independently using several classical DLLs with a normalized early-minus-late-power (EMLP) discriminator. The shortest tracked delay is then used to form the pseudorange measurement.

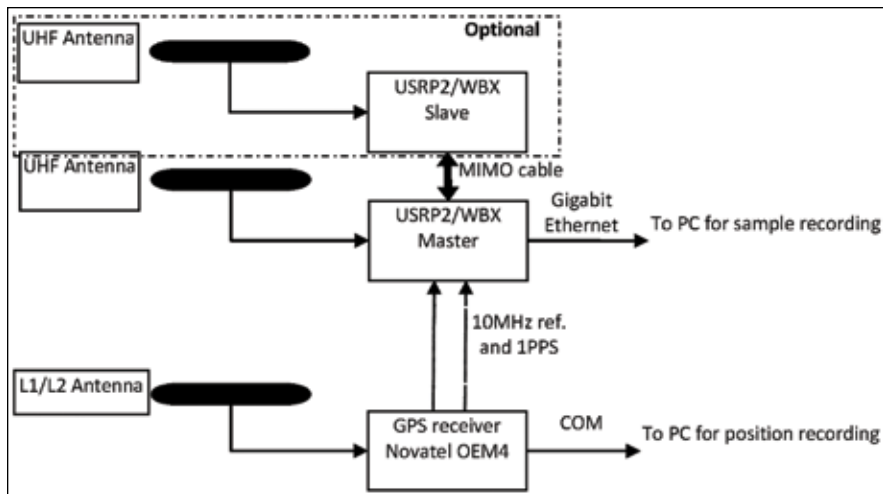

FIGURE 7 Block diagram of the test bench

Specific detectors are used to minimize the number of replicas tracked.

Note that the correlation function shown in Figure 6 presents significant side-lobes, which can lead to significant impairments due to the near-far effect, particularly in SFNs. To mitigate this, we can use windowing techniques in order to reduce the correlation side-lobes, as tested in the work described in P. Thevenon *et alia* (2011).

To assess the ranging performance in a realistic terrestrial channel, we considered the use of multipath channel models. Unfortunately, the existing models found in the literature are systematically dedicated to telecommunications or broadcast applications and, consequently, they focus only on the modeling of multipath power and not on the fine modeling of the multipath delay.

To handle this lack of model, in an earlier work P. Thevenon used the output of a measurement campaign realized by the French Space Agency (CNES) to characterize the urban channel for a DVB-SH transmission system. (DVB-SH is a standard based on the DVB-T made for handheld devices, in the 2.2-GHz band using one satellite and several terrestrial emitters in a SFN). Based on this estimated propagation channel, P. Thevenon created a semi-realistic simulation environment based on the assumption that the multipath amplitude followed a Rayleigh distribution.

This multipath channel is applied to a simulated DVB-SH signal and the

ranging estimations are done on this semi-simulated signal. This work shows very hopeful results with a ranging error standard deviation of a few 10s of meters, and a 2-D positioning accuracy in the range of 30 to 50 meters (standard deviation) in a mid-sized French city, based on three emitters (one satellite + two terrestrial emitters). A significant source of error during the tests likely came from the fact that the direct signal was blocked most of the time.

However, even if the generated signals had been based on a real measurement campaign, some uncertainties still remain regarding the employed multipath channel because of hardware constraints during the measurement campaign (only six multipath delays estimated, limited sensitivity) and doubts about the representativeness of the chosen multipath amplitude generation.

Thus, to confirm the strong results obtained in this work, we decided to perform additional tests on real signals based on DVB-T.

### The DVB-T Test Bench

Our DVB-T test bench, represented in Figure 7, is composed of:

- one dual-frequency GPS receiver to record a reference position and provide GPS time to the rest of the test bench for system synchronization
- two TV signal recording devices (one optional), incorporating a software radio that enabled reception

of signals from two independent TV antennas, to digitize them at the desired sampling frequency and send the samples to a host PC to be recorded on a hard drive.

One function of the recording device is to tag the recorded samples with the GPS time. Thus, the precise reception time of the samples is known and can be associated with the reference trajectory. This test bench has been developed to be flexible (with all the reception parameters — such as carrier frequency, sampling frequency, and gain — being configurable) and allows the following test configurations:

- two mobile TV antennas receiving the same signal to exploit antenna diversity and improve measurement quality (Indeed, in a dense multipath environment, each antenna can have very different reception conditions, even if they are located very close together.)
- two mobile TV antennas receiving two signals at different frequencies from the same emitter to exploit frequency diversity
- two mobile TV antennas receiving two signals at different frequencies from two emitters to have two PR measurements
- one fixed antenna and one mobile to perform differential measurements.

The test bench can also easily be modified to receive other SoO signals.

### Tests on Real Signals

Tests of the proposed ranging technique based on real signals have been performed in Toulouse, France, using two emitter configurations, both found in southwestern France:

- an urban test using one emitter precisely synchronized to GPS time (at  $\pm 30$  nanoseconds)
- suburban and urban tests using two emitters in an SFN not precisely synchronized to GPS time.

The DVB-T parameters used in France are (with reference to Table 1): mode 8K, eight-megahertz bandwidth, CP ratio of 1/8, and data symbol modulated using 64-QAM. The possible transmitted frequencies are 474 MHz +

$(k - 21) \cdot 8 \text{ MHz}$  where  $k \in \{21, \dots, 69\}$  is the channel number and  $f_{\text{offset}} = 166.667 \text{ kHz}$ .

The test bench is mounted in a car. Thus, the tests are dynamic scenarios, even if static phases can be present when the car is stopped at a traffic light. The following sections describe the results of two test cases.

**Case 1: Urban Test Using Digital TV Emitter Synchronized with GPS Time.** Five tests were performed in this environment, all leading to results of the same order. Thus, we will present only the longest one here. In this experiment, the car was driven for 5 minutes in an urban environment with the test bench set up to record the data from two closely-spaced TV antennas (about one meter apart) on the roof of the car.

The two TV antennas were tuned to receive a TV signal (at 762.16667 MHz) from an emitter of 8kW effective isotropic radiated power (EIRP) located about 80 kilometers from the test zone. **Figure 8** shows the trajectory of the vehicle during the test. It includes three static phases (at 0–10 seconds, 70–110 seconds, and 285–300 seconds). During the remaining time, the car speed ranged between 0 and 50 km/h.

Preliminary tests have shown that the clock of the TV emitter used in this test was synchronized to GPS time. Thus, because the test bench also uses GPS time as its reference, the measured PR is virtually clock error-free. However, as the emitted TV signal was not



**FIGURE 8** Car trajectory during test Case 1

phase-locked on GPS time, the phase offset between the emitter time and GPS time had to be determined in order to be able to derive the absolute PR measurement from the measured delay. This was done empirically by making a delay measurement in an open location with direct sight to the emitter.

The left panel of **Figure 9** presents the evolution of the absolute value of the correlation function overtime. We can view this as an estimate of the channel impulse response over time. The color scale represents the relative amplitude of the absolute value of the correlation function in decibels, 0 dB being the maximum amplitude over the whole image.

This figure is interesting because it outlines the various characteristics of the channel: presence of multipath, fading, and so forth. It also underscores that throughout the test, the direct signal or a short replica of it are present and dominant.

The right panel of **Figure 9** shows the estimated pseudorange for each TV antenna compared to the reference PR computed from the GPS-based (real-time kinematic or RTK) car position and the known emitter location. One can see that the error is mostly positive — a clear indication of non-line-of-sight (NLOS) error. We can also see that the errors associated with each antenna are very different (up to 150 meters) even if they

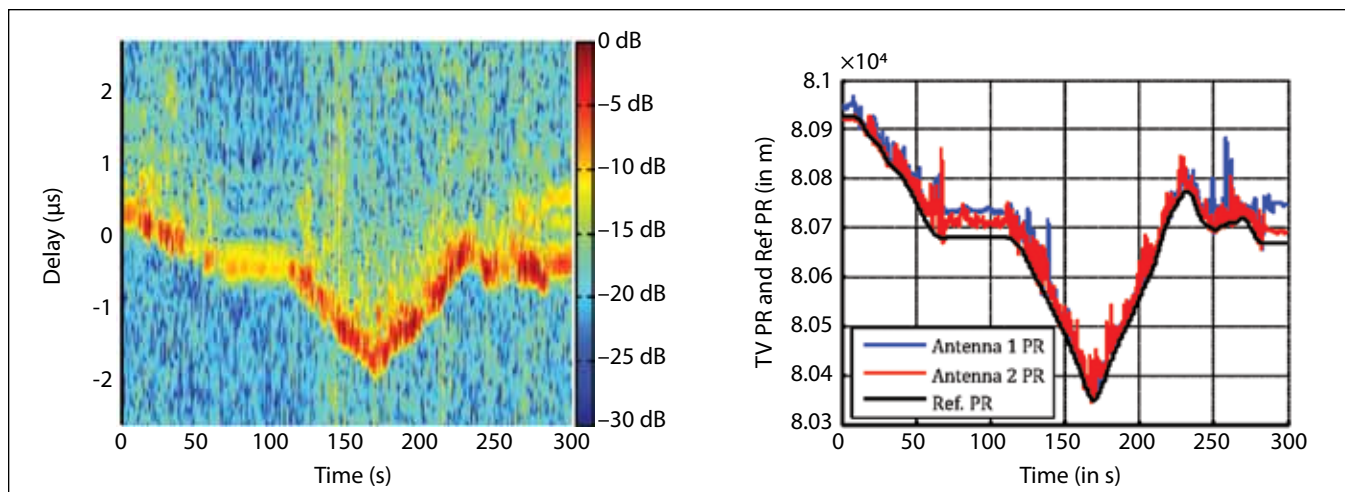

**FIGURE 9** Correlation image (left) and estimated pseudorange compared to reference pseudorange (right)

	Antenna #1 PR	Antenna #2 PR	With advanced measurements processing
Mean Tracking Error	35 m	25 m	4 m
Tracking error standard deviation	25 m	20 m	10 m

TABLE 2. Summary of the tracking performance in text Case 1



FIGURE 10 Trajectories of the suburban (up) and urban (down) tests in Case 2

are close (separated only by one meter).

The tracking error statistics are summarized in Table 2. Both antennas present a ranging error standard deviation of about 20 meters. The mean values are respectively of 35 meters and 25 meters, slightly better for the second antenna due to a smaller error during the static phases.

An advanced measurement processing technique to reduce the NLOS error was also tested, providing a significant improvement, as shown in Table 2. This represents excellent and promising results.

**Case 2: Suburban and Urban Tests Using Two Digital TV Emitters in SFN and not Synchronized with GPS Time.** In these two experiments, the car was driven for 90 seconds in suburban (first experiment) and urban (second experiment) environments. The recording device, used in its

single antenna version (the dual-antenna version not being available at the time) was tuned to receive a TV signal (at 706.16667 MHz) from two emitters in the SFN.

The first emitter had an EIRP of 13 kilowatts and was located 100 kilometers away from the test zone. The second emitter had an EIRP of 24 watts and was located about 5 kilometers away from the test zone.

Figure 10 shows the trajectories followed during the two tests. For the urban test, due to adverse reception conditions of the GPS signal, the accuracy of the reference trajectory was sometimes poor (standard deviation of several meters); thus, results must be considered accordingly.

We analyzed the clocks of the two emitters and observed that they were not synchronized with GPS time. However,

because the two emitters belong to an SFN, they shared the same clock; thus, we could obtain error-free clock measurements by forming time-difference-of-arrival (TDOA) measurements (difference between the estimated delays of Emitter #1 and Emitter #2).

Figure 11 shows the TDOA measurement errors for the suburban experiment and the urban experiment. In both cases, the average value of the TDOA measurement error is null by construction. The standard deviation of the TDOA error is about 5.2 meters in the suburban test and 16 meters in the urban test.

As expected the results in the suburban environment are better than in the urban environment thanks to less intense multipath conditions. Most notably, the level of errors is extremely encouraging considering the environment.

### Conclusions and Future Work

A ranging method, adapted to the OFDM-based DVB-T signal and taking into account the specificities of the terrestrial propagation channel, has been presented and tested on real signals in this article. The test bench is a flexible one that can be used with two antennas and record signals from several emitters.

The test results show that the proposed ranging method induced a ranging error with a standard deviation of about 20 meters and a bias of about 25 meters, mostly due to the presence of NLOS signals and blockage of the direct signal. We have also shown that use of an advanced measurement processing technique could significantly improve these results to below 10 meters. Consequently, and despite the intense multipath environment of the test cases, this study demonstrates the feasibility of positioning using DVB-T (and more generally OFDM-based signals, although it is difficult to generalize the expected accuracy).

The continuation of this work includes the adaptation of the method to other OFDM standards. Indeed, DVB-T is not the most suitable standard for a final application, because it is not sized for mobile reception and offers a weak density of emitters. The future mobile



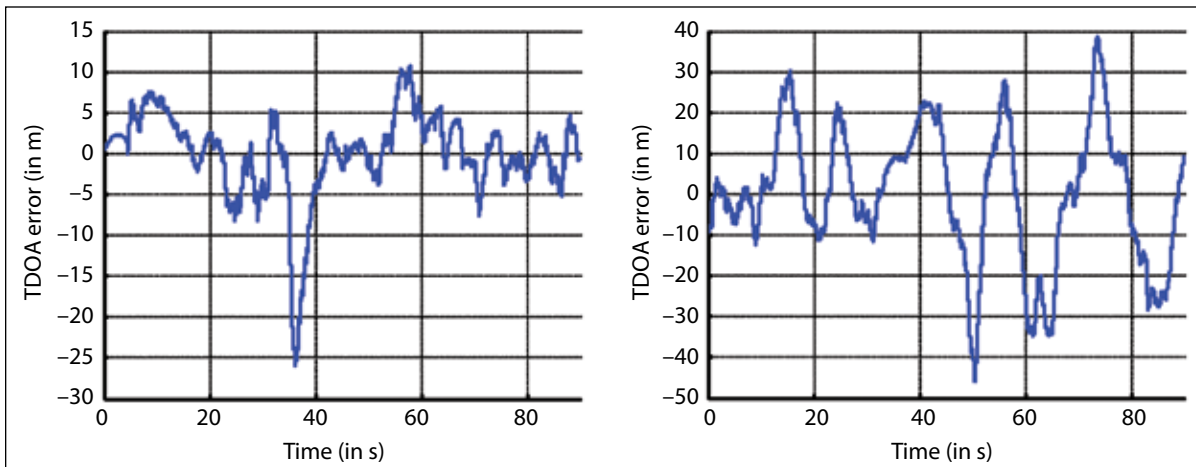

FIGURE 11 TDOA measurement error for suburban (left) and urban (right) environments in test Case 2

telephony standard 3GPP Long Term Evolution (LTE) could be an interesting candidate. Such a mobile application could permit better reception in urban environments and indoors (also not a problem with DVB-T) with the advantage of a high emitter density that would increase the number of PR measurements.

Another extension of this work involves the hybridization of OFDM-based ranging measurements with GNSS measurements.

## Acknowledgements

The authors would like to deeply thank the French Space Agency (CNES) and Thales Alenia Space France for funding this research.

## Manufacturers

The GPS receiver used as a reference in the field tests was an OEM4 ProPack G2-Plus from **NovAtel, Inc.**, Calgary, Alberta, Canada. The software receiver was a USRP2 from **Ettus Research LLC**, Mountain View, California, USA.

## Additional Resources

[1] Chiueh, T. D., and P.-Y. Tsai, *OFDM Baseband Receiver Design for Wireless Communications*, John Wiley & Sons (Asia) Pte Ltd, 2007

[2] Cotter, S. F. and B. D. Rao, "Sparse channel estimation via matching pursuit with application to equalization," *IEEE Transactions on Communications*, vol. 50, no. 3, p. 374–377, 2002

[3] DVB Worldwide [Online], available at <[http://www.dvb.org/about\\_dvb/dvb\\_worldwide](http://www.dvb.org/about_dvb/dvb_worldwide)>

[4] ETSI EN 300 744 V1.6.1: Digital Video Broadcasting (DVB); Framing structure, channel coding and modulation for digital terrestrial television, 2009

[5] Ettus Research LLC [Online], available at <<http://www.ettus.com>>

[6] Li, Y., and G. Stüber, *Orthogonal Frequency Division Multiplexing for Wireless Communications (Signals and Communication Technology)*, Springer, 2006

[7] Liu, S. Y., et J. W. Chong, « A study of joint tracking algorithms of carrier frequency offset and sampling clock offset for OFDM-based WLANs », in *IEEE 2002 International Conference on Communications, Circuits and Systems and West Sino Expositions*, vol. 1

[8] Morelli, M., and C. Kuo and M. Pun, "Synchronization Techniques for Orthogonal Frequency Division Multiple Access (OFDMA): A Tutorial Review," *Proceedings of the IEEE*, vol. 95, no. 7, pp. 1394–1427, 2007

[9] Paulraj, A., and R. Roy and T. Kailath, "Estimation of Signal Parameters via Rotational Invariance Techniques-ESPRIT," *proceedings of Nineteenth Asilomar Conference on Circuits, Systems and Computers*, 1985, pp. 83–89

[10] Serant, D. (2010a) and L. Ries, P. Thevenon, O. Julien, C. Macabiau, M. Dervin, and M-L. Boucheret, "Use of OFDM-based digital TV for ranging: Tests and validation on real signals," 5th ESA Workshop on Satellite Navigation Technologies (NAVITEC) and the European Workshop on GNSS Signals and Signal Processing, Noordwijk, The Netherlands, 2010

[11] Serant, D. (2010b), and P. Thevenon, M-L. Boucheret, O. Julien, C. Macabiau, S. Corazza, D. Mathieu, and L. Ries, "Development and validation of an OFDM/DVB-T sensor for positioning," in *Proceedings of the Position Location and Navigation Symposium (PLANS)*, 2010 IEEE/ION, 2010, pp. 988–1001

[12] Thevenon, P., *S-band air interface for navigation systems: a focus on OFDM signal*, Ph.D. thesis, Université de Toulouse, 2010

[13] Thevenon, P., (2009a), and O. Julien, C. Macabiau, D. Serant, L. Ries, S. Corazza, and M. Bousquet, "Positioning Principles with a Mobile TV System Using DVB-SH Signals and a Single Frequency Network », in *proceedings of 16th International Conference on Digital Signal Processing*, pp. 1–8, 2009

[14] Thevenon, P., (2009b), and O. Julien, C. Macabiau, D. Serant, S. Corazza, M. Bousquet, L. Ries, and T. Grelier, "Pseudo-Range Measurements Using OFDM Channel Estimation", *ION GNSS 2009*, Savannah, Georgia, USA

[15] Thevenon, P., (2011) and D. Serant, O. Julien, C. Macabiau, M. Bousquet, L. Ries, and S. Corazza, Stéphane « "Positioning Using Mobile TV Based on the DVB-SH Standard," *NAVIGATION: Journal of the Institute of Navigation*, Summer 2011, pp. 71–90

## Authors



**Damien Serant** is currently working in the navigation department of Thales Alenia Space – France as a GNSS signal processing engineer. He is also finishing its Ph.D

thesis on positioning with OFDM signals, undertaken in the signal processing lab of the French Civil Aviation University (ENAC) and co-funded by the French Space Agency, CNES, and by Thales Alenia Space. He graduated as an electronics engineer from the ENAC, in Toulouse, France.



**Olivier Julien** is an assistant professor at the signal processing laboratory of ENAC. His research interests are GNSS receiver design, GNSS multipath and

interference mitigation, and GNSS interoperability. He received his B.Eng. in digital communications from ENAC and his Ph.D. from the Department of Geomatics Engineering of the University of Calgary, Canada.



**Lionel Ries** has been a navigation expert in the Transmission Technique and signal processing (TT) Department at CNES since June 2000, where he coordinates navigation technical activities. He is responsible for research activities on GNSS2 signals, ground and spaceborne receivers, payloads, and systems. He contributed to the invention of the composite binary offset carrier (CBOC) signal. Ries provided support to the 2004 US-EU agreement on GPS and Galileo. He was responsible for the development of the L1-L2C signal processing algorithms now implemented in the ASIC and processor of the TOPSTAR 3000 receiver, in the frame of a CNES R&D activity. He graduated from the Ecole Polytechnique de Bruxelles, at Brussels Free University, and received an M.S. degree from the Ecole Nationale Supérieure de l'Aéronautique et de l'Espace (Supaero) in Toulouse.



**Paul Thevenon** is a GNSS engineer in the GNSS signal processing team of CNES (Centre National d'Etudes Spatiales), the French space research center. He graduated as electronic engineer from Ecole Centrale de Lille and obtained a research master at ISAE (Institut Supérieur de l'Aéronautique et de l'Espace) in space telecommunications. Thevenon later obtained a Ph.D. degree in the signal processing laboratory of ENAC (Ecole Nationale de l'Aviation Civile) in Toulouse, France, studying the feasibility of self-positioning a receiver using mobile TV signals. His current activity is GNSS signal measurement and processing, with an emphasis on urban environment.



**Mathieu Dervin** has been with the research department of Thales Alenia Space in Toulouse, France, since 2006. He is carrying out technical studies to prepare the future space telecommunication systems. His research interests cover advanced digital com-

munication techniques applied to the satellite transmissions, and include waveform and receiver architecture design. He received an engineering degree and a Ph.D. degree in communications, both from Télécom ParisTech.



**Guenter W. Hein** serves as the editor of the Working Papers column. He is head of the Galileo Operations and Evolution Department of the European Space Agency. Previously, he was a full professor and director of the Institute of Geodesy and Navigation at the University FAF Munich. In 2002 he received the prestigious Johannes Kepler Award from the U.S. Institute of Navigation (ION) for "sustained and significant contributions to satellite navigation!" He is one of the CBOC inventors. 



The Institute of Navigation

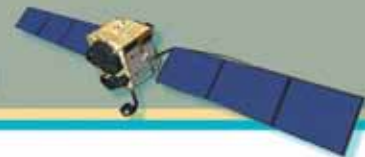

# 2012 International Technical Meeting

**January 30 – February 1, 2012**  
**Newport Beach Marriott Hotel & Spa**  
**Newport Beach, California**

Partial list of session topics:

- Algorithms & Methods
- Alternate Sensors & Systems
- Atmospheric Effects
- Autonomous Navigation/Robotics
- Aviation Applications
- GNSS Modernization
- History of Navigation
- Maritime Applications
- PNT Applications
- Receivers & Antenna Technology
- Remote Sensing Using GNSS
- Space Applications
- Spectrum & Interference Issues
- Timing Applications
- Urban & Indoor Applications
- QZSS



Visit [www.ion.org](http://www.ion.org) for More Information